

# Non-Ferrous Metals Recovery From Municipal Waste Combustor Ash

**Art Shelko**

Ogden Energy Group

40 Lane Road

Fairfield, NJ 07007-2615

## **ABSTRACT**

The combustion of municipal solid waste (MSW) typically reduces the volume of material that is eventually landfilled to approximately 10% of the incoming volume. The recovery of ferrous metal from the combustion residue can reduce this volume to around 5% of the received MSW as well as add to the facility's economics by producing a saleable product. The recovery of non-ferrous metals not only further decreases the amount of ash going to a landfill but can also add significantly to the facility's bottom line.

This paper examines the engineering and construction challenges encountered with the retrofit of a non-ferrous metals recovery system into an operating facility without interruption of the facility's ongoing operations, as well as some operational problems encountered with such a system. The paper is based on the experience gained by retrofitting a non-ferrous metals recovery system into the heart of Ogden Energy Group's 3,000 tons per day (TPD) mass burn facility in Fairfax County, VA.

## **INTRODUCTION**

A Resource Recovery Facility (RRF) serves several functions. The most obvious purpose of a Waste To Energy (WTE) plant is to dispose of municipal solid waste (MSW) by burning it in a Municipal Waste Combustor (MWC). This provides an efficient and environmentally sound method of disposing of the millions of tons of MSW produced each day.

However, as a Resource Recovery Facility, a WTE plant does more than just provide for the burning of trash; it must also, as the name implies, recover resources from the trash wherever feasible. By using the heat of combustion to produce steam and electricity the amount of oil that the United States must import is reduced substantially. And the recovery of ferrous metals from the combustion residue allows this material to be gainfully recycled.

Until recently, this was the extent of recovering resources - material or energy - in a WTE plant. However, recent technological developments in the effectiveness of eddy current separators (ECSs) created the potential of recovering non-ferrous metals, such as aluminum, copper, brass and coin, from the residue.

## **EDDY CURRENT SEPARATORS**

The idea of using magnetic force to capture non-ferrous metals sounds a bit far-fetched; yet, in effect, this is precisely what an ECS does.

You may recall three basic laws of physics (see Fig.1): 1) when a conductive material is passed through a magnetic field an electric current is induced in the conductor; 2) when a current flows through a conductor it creates or induces a magnetic field around the conductor; and 3) like magnetic poles repel. With the first law, the strength of the induced current depends on the strength of the magnetic field and the relative speed that the conductor passes through the field. With the second, the polarity of the induced magnetic field is the same as that of the magnetic field being cut, i.e. like poles.

An eddy current separator consists essentially of two components: a belt conveyor and a multi-pole magnetic rotor. The belt moves at a relatively fast pace, typically 400-450 feet per minute (fpm). The

magnetic rotor, which typically is constructed from high strength but short field rare earth magnetic material, rotates at high speed - typically 1800 rpm or more. The magnetic rotor rotates inside of, but is physically separate from, the head pulley.

Ash is fed onto the belt at as even a flow as practical. The high speed of the belt imparts a trajectory to the ash when it is discharged from the belt at the head pulley.

The non-conductive ash is unaffected by the magnetic rotor spinning inside of the head pulley. However, when a piece of conductive material passes over the head pulley the magnetic field that it passes through induces a current in it. This in turn creates a magnetic field, identical in polarity to the field being cut. Since like poles repel, the conductive material is given an extra "kick" compared to the non-conductive particles. And, since the multi-pole rotor is turning at a much greater speed than the belt, the constantly alternating polarity of the magnetic fields imparts this kick numerous times. The result is that the conductive material is thrown farther from the head pulley than is the non-conductive ash. An adjustable splitter separates the two streams, allowing the conductive non-ferrous material to be isolated.

## **ASH PREPARATION AND HANDLING**

For the non-ferrous metals recovery system to operate efficiently several things are necessary. While it is acceptable for the ash to be damp it should not be sticky. Although the system is batch-operated, it should be operated at as consistent a flow rate as possible. All ferrous material must be removed from the ash. And the ash should be sized to eliminate material that is either too large or too fine to be properly processed.

The Fairfax ash consists of a mix of bottom residue and fly ash. The fly ash contains spent reagent and lime from the flue gas scrubbers, which increases the moisture content and hence the stickiness of the ash. Experience has shown that, in general, if the ash is aged for about five days the sticky characteristic is reduced and the ash can be processed more effectively than fresh ash.

The Fairfax facility combusts 3,000 tons per day of MSW. At an average ash content of 25%, this generates 750 tons per day of residue that must be stored for five days. Designing a new facility that could store 35-40,000 tons of ash could present a challenge; retrofitting this storage capacity into an existing operating facility, along with a new system, made life interesting. The problem was resolved by extending the existing Residue Handling Building.

The Fairfax facility operates twenty-four hours a day, 365 days per year. The existing ash handling and ferrous recovery systems operate on a continuous basis. However, it was decided to operate the non-ferrous metals recovery system on a batch basis, approximately one shift per day, five days a week. The batch operation allows daily maintenance of the equipment, and lends itself to the five day ash storage arrangement. However, the system itself obviously operates most efficiently when ash is fed on a continuous basis; surges in ash flow can have a negative impact on operating efficiency and equipment performance.

## **SYSTEM OPERATION**

Figure 2 is a flow diagram of the system installed at the Fairfax facility.

Material is fed into a hopper by a front end loader. The hopper feeds onto a vibratory feeder. The stroke of the feeder and, above all, the operation of the front end loader are of paramount importance to smooth and proper operation of the system.

The vibratory feeder discharges onto an inclined belt conveyor which elevates the ash to the height required to allow for adequate storage of the ash components after processing. The belt conveyor discharges onto a vibratory spreader/feeder.

As stated above, the heart of the ECS is a strong rotary magnet. While this magnet produces the eddy currents in the non-ferrous conductive materials that result in the *non-ferrous* metals being repelled, any *ferrous* material in the ash would not be repelled but would instead be strongly attracted to the rotor. The

## NON-FERROUS METALS RECOVERY FROM MUNICIPAL WASTE COMBUSTOR ASH

magnetic attraction could be strong enough to prevent the ferrous from being thrown from or dropping off the belt, causing it to roll or slide on the belt above the rotor. This would cause the ferrous to heat up, possibly to the point of becoming red hot, damaging not only the belt but the magnetic rotor assembly as well. Thus it is imperative that all ferrous material be removed from the ash before it is fed onto the ECS.

Although the Fairfax facility was built with a ferrous recovery system, the sheer size of the facility indicates that some ferrous will get by. Therefore, a large permanent magnetic drum separator was installed as part of the non-ferrous metal recovery system. This primary drum magnet removes all but the finest ferrous remaining in the ash.

Experience has shown that most non-ferrous metal in MSW ash is smaller than two inches in size. Exceptions to this are much larger pieces, such as catalytic converters and beer kegs, which are removed upstream by a grizzly-scalper and recovered by hand. Experience has also shown that material smaller than 1/4"-3/8" is not readily recoverable. To sort the ash to be processed by size a double deck double oscillation screen was added downstream of the primary drum magnet. The top deck scalps all material too large to pass through the 2" diameter screen openings. All residue smaller than 2" drops to the lower deck of the screen. The lower deck was furnished with 3/8" slotted openings; this was later changed to 1/4". Fine material falls through the lower deck to a storage compartment below. Material too large to pass through the lower deck is discharged to a downstream vibratory spreader/feeder.

As stated above, it is critical that all ferrous be removed from the ash before the ash passes onto the ECS. While most of the ferrous has been removed by the ferrous system and the upstream primary magnetic drum separator, there may be a small amount of fine ferrous still remaining in the residue after the magnets and after screening. This is removed by a secondary or fines magnet located immediately upstream of the ECS.

Each ECS manufacturer has his own requirements for the fines magnet. Some require a rare earth drum with the ferrous flow "down and under"; others require a ceramic magnet with the ferrous traveling "up and over". At Fairfax we used a 36 inch diameter ceramic permanent magnet drum, with flow up and over, purchased from the ECS manufacturer.

Ash passing under the fines magnetic drum discharges via a vibratory feeder pan onto the ECS.

## **RETROFIT CONSTRAINTS**

The first problem encountered in retrofitting the new non-ferrous metals recovery system into an existing facility was location. The Fairfax facility is, by all standards, a large facility. There are four units, each rated at 750 tons per day of MSW, with space reserved for a future similar size fifth unit. However, as with any well-planned facility, the available real estate was utilized efficiently for the original plant and the *planned* future expansions. As a result, adding a large, unanticipated new system to the middle of the plant was hindered by existing and planned equipment, buildings and underground utilities.

As stated above, the existing ash building was extended to the maximum extent possible to increase ash storage capacity. This provided sufficient space to age the ash prior to processing it in the non-ferrous metals recovery system. This aging would not be required for normal ash processing or for recovery of just ferrous metals.

Along with the building extension it was necessary to modify one of the two existing overhead vibrating ash distribution conveyors and to add additional dropout gates to transport ash to the new storage area. The extended conveyor then had to be re-tuned. All of this had to be accomplished without shutting down the existing ash handling system since the facility continued to operate around the clock.

A new building was added to house the non-ferrous metals recovery system. The new building was added to the northeast section of the existing building. All new equipment was housed in the new building which became, for all practical purposes, an extension of the existing ash handling building. The space for the building extension was constrained by an existing and a future boiler on the north, by future air pollution control (APC) equipment to the east, by a roadway, a cooling tower and the existing ash building to the south

and by the existing inclined belt conveyor gallery to the west.

As stated previously, ash is loaded via a hopper onto a vibratory feeder. The feeder meters the ash onto the inclined belt conveyor which in turn feeds the ash via the vibratory spreader/feeder to the primary magnet. Ideally, from a materials handling point of view, all this equipment should be mounted in-line to minimize the potential for spillage and to spread the ash across the full width of the conveying equipment and the magnet. Because of space restrictions the vibratory feeder, which moves the ash in the east direction, transfers onto the inclined belt at 90°, with flow to the north, rather than continuing in-line to the east. Likewise, the inclined belt conveyor dumps onto the spreader/feeder perpendicularly, with the direction of flow now to the west.

At the feeder to inclined belt transition the right angle transfer results in occasional spills. More importantly, the ash, which is spread across the full width of the feeder, does not always load evenly onto the belt. This means that the ash does not always load evenly onto the spreader/feeder which, in turn, means that ash does not always load across the full width of the primary magnet.

If the inclined belt conveyor and spreader/feeder were in-line, with a 90° directional change after the magnet, it would have been possible to allow the recovered ferrous to drop directly to the storage area below. Two feeder pans would have been required: a spreader/feeder to convey the ash to the drum magnet, and a second to convey the residue to the oscillating screen. Recovered ferrous would then fall directly to the storage area below. With the space constraints forced by the retrofit, three pans are necessary at the magnet: the two described above plus a third pan to carry away the recovered ferrous.

Space constraints in the east-west direction further complicate operations. The relatively short spreader/feeder pan does not always spread the ash evenly across the full face of the seven foot wide drum magnet. Recovered ferrous must be plowed off the ferrous pan. The eight foot wide pan requires a double plow which in turn requires two chutes to direct the ferrous to two dropout points below.

To consolidate equipment where possible the three pans were combined to operate off a common vibratory drive. Interfacing between the triple combination feeder, the drum magnet and the inclined belt conveyor, all of which came from different manufacturers, created some interesting design and installation challenges. However, other than the “usual” startup problems, the equipment has performed well.

A similar although smaller feeder arrangement was used at the fines magnet.

Our normal design practice is not to exceed 16° maximum pitch on an inclined belt conveyor. Even stretching this to 18° we encountered a problem with feeding ash into the in-feed hopper due to the north-south space constraint. This can best be explained by starting at the end of the system - the eddy current separator. To facilitate removal of reject ash from under the ECS the bottom of the ECS was set twelve feet above the floor. Working upstream from this point the minimum slopes of the vibratory feeders and the oscillating screen set the elevation of the inclined belt conveyor head pulley. The north-south constraint set the location of, and consequently the elevation of, the tail pulley. Even with the sloped vibratory feeder as short as practical the top of the in-feed hopper was too high for the front end loader. A ramp with a 20% grade had to be constructed for the loader. Although steep, the loader has been able to negotiate this without incident.

## **OPERATIONAL CONSTRAINTS**

As previously mentioned the system operates approximately one shift a day, five days a week. This allows adequate time for cleanup each day and for daily equipment maintenance. As with any ash handling system daily maintenance is a must. Keeping ahead is far easier than trying to play catch-up.

The two key items to successful operation are the rate of feed into the system and the condition of the ash being processed.

Material is fed into the system in batches by a front end loader. The system operates most effectively when the flow of material across the magnets, screen and ECS is constant. Therefore it is imperative that the loader operator understands that ash must be “feathered” into the hopper so that the feeder can even out



## NON-FERROUS METALS RECOVERY FROM MUNICIPAL WASTE COMBUSTOR ASH

the peaks and maintain as smooth and constant a flow as possible onto the inclined belt conveyor.

Ash condition is also critical. It should be apparent that a heavy accumulation of ash on the recovered metal will directly impact the market price of the material and could even render it non-saleable. However, even ash that is not adhering heavily to the metal can greatly affect the performance of the eddy current separator if it builds up on the ECS belt. To appreciate this, one must have an understanding of how rare earth magnetic material reacts.

Although pound for pound a rare earth magnet is far stronger than a ceramic or ferritic magnet, it has a very short field depth. This is illustrated in Fig. 3. Hold a piece of steel twelve or even fifteen inches away from a ceramic magnet, such as the primary ferrous magnet in our system and you will feel the magnet pulling on it. A rare earth magnet, on the other hand, has a field depth of two inches at best. Now consider that the ECS magnetic element is surrounded by a fiberglass or similar wrap, and that there is a head pulley over this and then a belt over the pulley and you can appreciate that under the best of conditions there is a certain minimum distance inherent between the surface of the magnetic element and the ash being processed. Now consider that the magnetic force falls off exponentially with distance and you can appreciate the major impact that the buildup of half an inch or so of sticky ash on the ECS belt will have on the recovery efficiency of the system. This explains why we went to the expense of providing storage space for five days of aging.

Similarly, if material is allowed to surge onto the ECS so that the bed is more than one particle thick, not only may the material on top be too far from the magnetic field to be repelled but the burden on top of the particles on the surface of the belt may be enough to prevent this material from being recovered as well.

### CONCLUSION

Recovery of non-ferrous metals from municipal waste combustor ash with an eddy current separator can be successfully accomplished. Ogden has one system in operation and several more on the way. The decision is one of simple economics: how much recoverable metal is in the ash, what is the market price, what will it cost to recover it, and what is the savings in hauling and landfilling costs. In addition, there is the intangible benefit of good "PR" gained by recovering and recycling additional material from the ash.

# THREE BASIC LAWS OF PHYSIC

1. WHEN A CONDUCTOR IS PASSED THROUGH A MAGNETIC FIELD AN ELECTRIC CURRENT IS INDUCED IN THE CONDUCTOR.

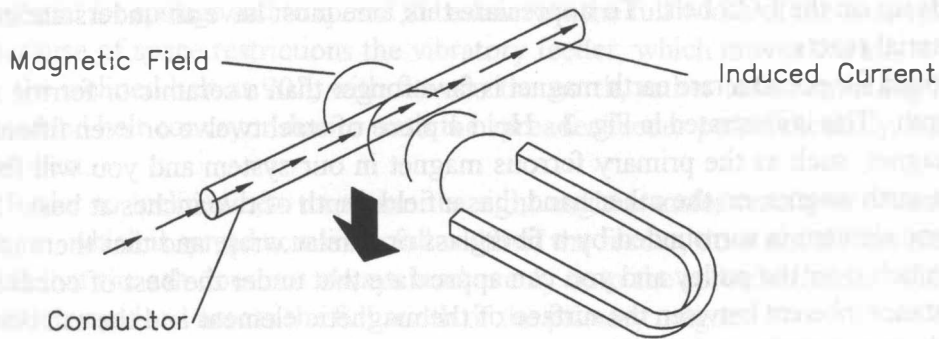

2. WHEN A CURRENT FLOWS THROUGH A CONDUCTOR IT CREATES A MAGNETIC FIELD AROUND THE CONDUCTOR.

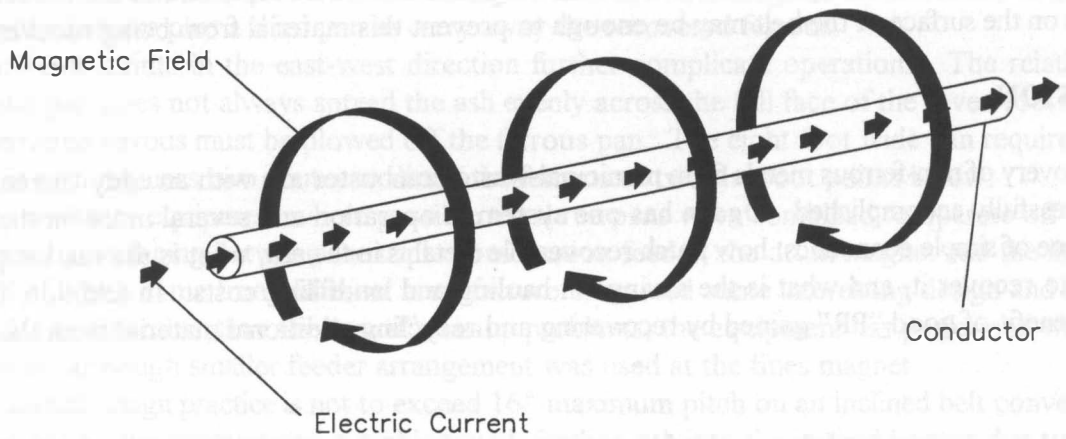

3. LIKE MAGNETIC POLES REPEL.

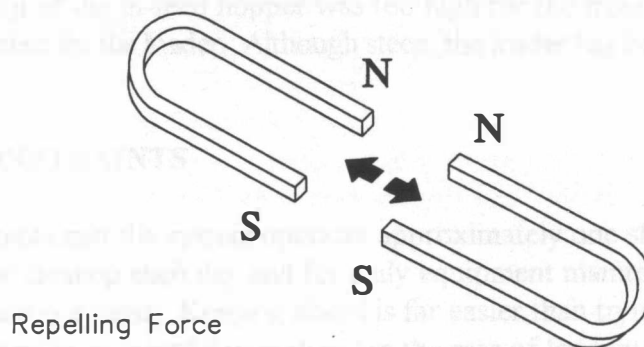

FIGURE 1

# NON-FERROUS METALS RECOVERY SYSTEM SIMPLIFIED FLOW DIAGRAM

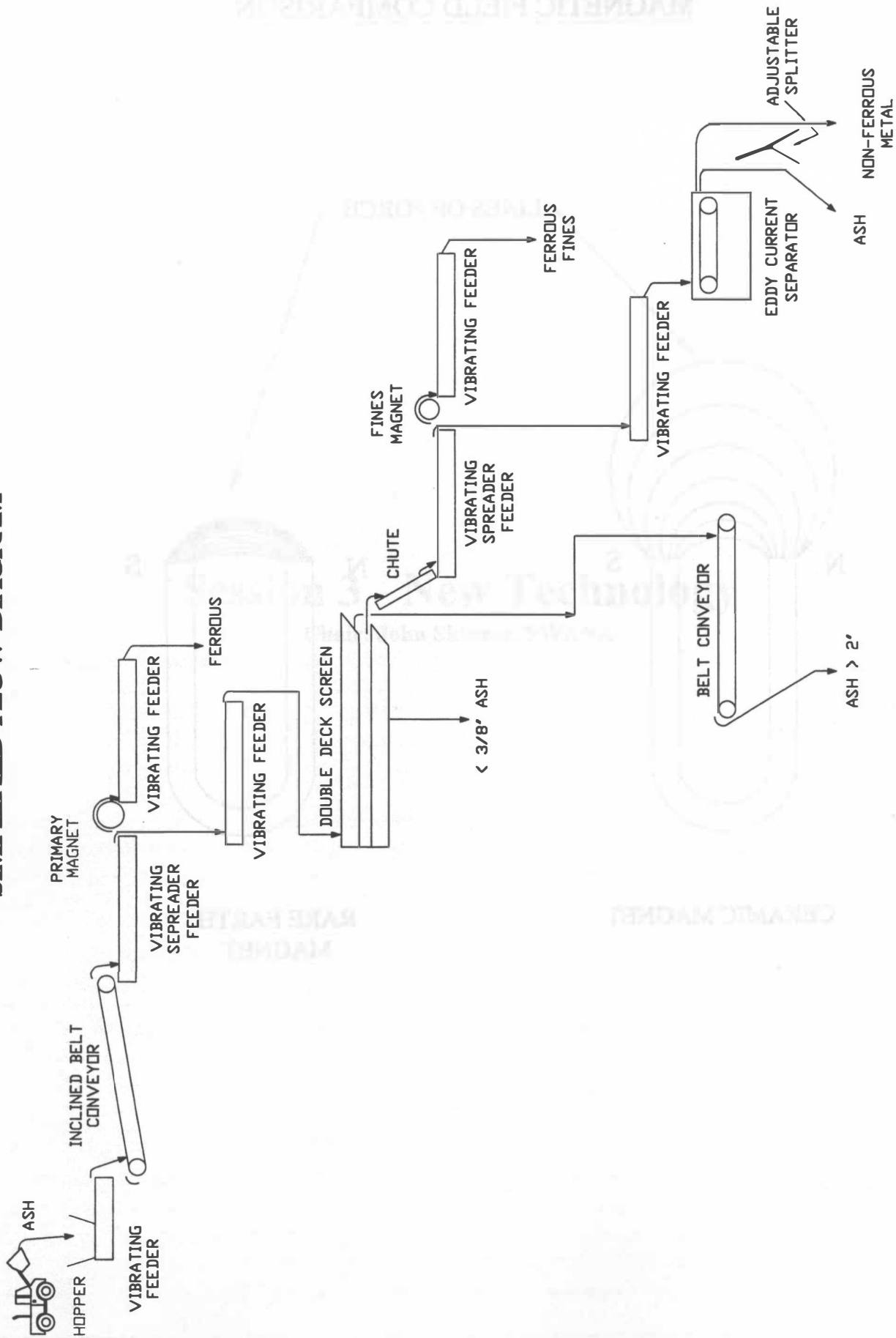
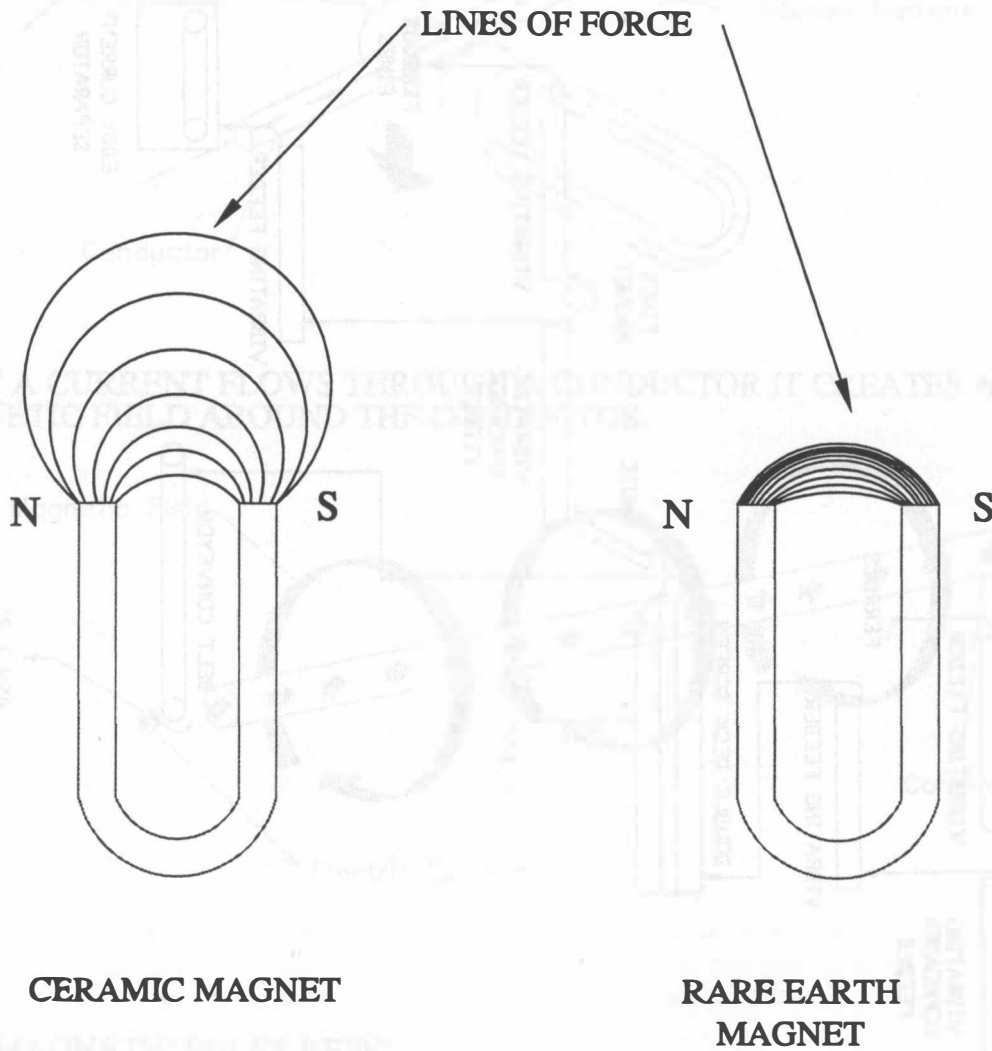

FIGURE - 2

# MAGNETIC FIELD COMPARISON



**FIGURE 3**