

A Study on Performance and Emissions of a 4-stroke IC
Engine Operating on Landfill Gas with the Addition of H₂, CO
and Syngas

A thesis submitted in partial fulfillment of the requirements for the
degree of Master of Science

Earth and Environmental Engineering

Jechan Lee

Dr. Marco J. Castaldi, Advisor

Department of Earth and Environmental Engineering (HKSM)
Fu Foundation School of Engineering and Applied Science
Columbia University in the City of New York

February 2010

© Jechan Lee 2010

ACKNOWLEDGEMENTS

I would like to thank Prof. Castaldi for giving me a chance to do a good research and for his guidance and support through my duration at Columbia University. Also, I wish to acknowledge CCL group members for their assistance and advising in the lab. Finally, I would like to acknowledge all my family and friends in Korea whom I have missed.

TABLE OF CONTENTS

List of Figures

List of Tables

1. Introduction

1.1. Landfill gas

1.2. Landfill gas utilization: landfill gas to energy

1.3. Direct utilization of landfill gas

1.3.1. Boiler, space heating, and industrial heating

1.3.2. Internal combustion engine

1.3.3. Gas turbine

1.3.4. Fuel cell

2. Literature review

3. Experimental design

3.1. Engine specification

3.2. Engine modification

3.2.1. Carburetor, fuel tank, and fuel pump

3.2.2. Air cleaner

3.2.3. Exhaust

3.3. Fuel and air supply

3.3.1. Gas flow measurement and control

3.3.2. Fuel mixing

3.4. Electrical load

3.5. Emission analysis

4. Experimental methods

4.1. Detailed procedure

4.2. Fueling conditions

4.3. Calculations

4.3.1. Engine efficiency

4.3.2. Equivalence ratio

4.3.3. Specific emission measure

5. Experimental results

5.1. Engine efficiency

5.2. Equivalence ratio

5.3. Exhaust gas temperature

5.4. Carbon monoxide

5.5. Total hydrocarbon

5.6. Oxides of nitrogen

6. Comparison to real field combustion systems

7. Conclusions

References

LIST OF FIGURES

Figure 1.1. Landfill gas reforming and synthesis gas mixing process

Figure 1.2. Schematic of landfill gas system

Figure 1.3. Schematic of fuel cell

Figure 3.1. Honda GC 160E-QHA engine

Figure 3.2. Modified cylinder barrel

Figure 3.3. Air cleaner detached from the engine

Figure 3.4. (a) Muffler (b) Added exhaust pipe

Figure 3.5. Fuel mixing system

Figure 3.6. PRAMAC EG2800 generator

Figure 3.7. (a) Load board block diagram (b) Load board

Figure 3.8. Wattsup Pro meter

Figure 3.9. Circuit diagram for the meter

Figure 3.10. ENERAC integrated emissions system Model 700

Figure 3.11. Schematic diagram of experimental setup

Figure 5.1. Engine efficiencies with electrical load

Figure 5.2. Equivalence ratio with electrical load

Figure 5.3. Adiabatic flame temperature with electrical load

Figure 5.4. CO emissions with electrical load

Figure 5.5. THC emissions with electrical load

Figure 5.6. NOX emissions with electrical load

Figure 6.1. Emissions of four different combustion systems

LIST OF TABLES

Table 1.1. General composition of landfill gas

Table 3.1. Specification of the tested engine

Table 3.2. Calibration equations of rotameters

Table 3.3. Performance specification of the generator

Table 3.4. Technical specification of Wattsup pro powermeter

Table 3.5. Specification of exhaust gas analyzer

Table 4.1. Landfill gas tests

Table 4.2. H₂, CO, and syngas addition tests

1. INTRODUCTION

Fossil fuels supply nearly 80% of world energy demand [1]. Burning of fossil fuel always has associated with it emissions in the forms of nitrogen oxides (NO_x), sulfur oxides (SO_x), carbon monoxide (CO), unburned hydrocarbons (UHC). These emissions have environmental impacts that are both local and global. Moreover, in recent years, air quality has become a severe problem in many countries, and the interest to replace fossil fuels with renewable and sustainable energy sources has increased for reducing CO_2 and methane emissions.

Landfill gas, a potential alternative energy source, is generated from anaerobic decomposition of municipal solid waste deposited in landfills. The main portion of landfill gas is mainly comprised of methane and carbon dioxide together with a smaller amount of oxygen and nitrogen and trace amounts of other gases as shown in Table 1.1. Methane is a highly potent greenhouse gas with a global warming effect almost 21 times greater than carbon dioxide when directly released into the atmosphere. Recently, landfill gas has attracted considerable interest as a source of alternative energy for generating heat, power or fuel with the benefit of reducing direct methane emission into the atmosphere, for example there have been about 450 LFGTE projects in the US [2]. However, there are some disadvantages in the use of landfill gas: composition changes considerably depending on the landfill condition, season, and the type of waste, corrosiveness, lower heating value, high maintenance issues and capital costs. Due to these disadvantages, landfill gas is sometimes not considered as a good sustainable energy resource. Hence, in order to effectively utilize the landfill gas, these problems must be adequately addressed through appropriate engineering and technological approaches.

In this research, a small spark ignition engine was operated using pure methane, a simulated landfill gas, and the addition of hydrogen and carbon monoxide, and these various

fuels were compared in terms of the engine performance and emissions for the purpose of assessing the efficient utilization and direct application of landfill gas.

1.1. Landfill gas

In the United States, around 340 million tons of municipal solid wastes are produced annually [3]. Among these wastes, approximately 14% is combusted for waste-to-energy, 22% is recycled, and 55% is sent to landfills [4]. Landfill gas is produced from the anaerobic decomposition of organic waste materials by bacteria following the reaction [5]:

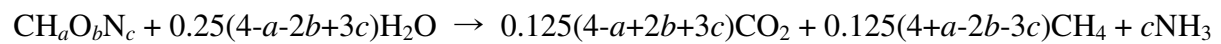

The general composition of landfill gas [5] is shown in Table 1.1.

Table 1.1. General composition of landfill gas

Constituents	% by volume
Methane	45 – 60
Carbon dioxide	40 – 60
Nitrogen	2 - 5
Oxygen	0.1 – 1.0
Ammonia	0.1 – 1.0
Hydrogen	0 - 0.2
Other trace gases (NMOCs)	< 0.6

The composition of landfill gas is highly dependent on the condition of landfill sites, the atmospheric moisture in the landfill area and the type of waste used in the landfill [3].

Landfill gas is an important source not only of volatile organic compounds (VOCs) but also of potent greenhouse gases [6]. The total amount of un-captured VOCs is about 2400 tons yearly [4]. Also, landfill gas is hazardous to vent to the atmosphere because it is highly explosive. More importantly, landfill gas is the second largest source of anthropogenic methane: 7.2 billion m³ per year [4]. However, with current practices, only 60% of methane

emitted from landfills is captured, the remaining 40% is emitted into the atmosphere [4]. Methane's global warming capacity is 21~23 times greater than the same volume of carbon dioxide. Because of these problems, landfill gas is flared in controlled conditions. This method prevents utilization of landfill gas as an energy source, instead the methane is converted to carbon dioxide, reducing the danger of explosion and the greenhouse effect. Rather than burning landfill gases, it is much more attractive to utilize it as a fuel to generate energy while addressing the environmental concerns at the same time [7].

1.2. Landfill gas utilization: landfill gas to energy

The landfill gas can be used as a fuel in industrial heaters, boilers, space heating, and engines for producing power and electricity because of the presence of methane. In the U.S., as of December 2007, there were 445 operational landfill gas to energy (LFGTE) projects generating a combined total of around 11 billion kWh of electricity per year [2]. According to recent research 42 million m³ of landfill gas were consumed in the generation of 66 million kWh of electricity [8]. Therefore, the improved utilization of landfill gas not only produces energy but also reduces greenhouse gas emissions, and also replaces fossil fuels, which are being depleted throughout the world.

As mentioned above, landfill gas consists of about 50% combustible gases (e.g. methane) and the remainder is incombustible gases (e.g. carbon dioxide and nitrogen). The average gross heating value of landfill gas is 476 Btu/ft³ (17,744 kJ/m³). Approximately 50% of landfill gas is composed of methane that has a gross heating value of 950 ~ 1,150 Btu/ft³ (35,415 – 42,871 kJ/m³). The high fraction of carbon dioxide in landfill gas is the most important factor in determining the combustion characteristics of landfill gas as a fuel. Carbon dioxide reduces flame temperature and the burning rate and limits flame stability, resulting in lower combustion efficiency and higher pollutant emissions.

There are various ways to improve landfill gas combustion efficiency and reduce pollutant emissions from landfill gas operation. The representative way is to increase the energy content of landfill gas by means of removing the CO₂, called “High Btu” gas process. The process uses pressure swing adsorption to remove much of CO₂ from landfill gas, producing a mixture with approximately 97% CH₄. The high Btu mixture is able to sold as natural gas [9].

It is another method to reform a portion of landfill gas used as a fuel to synthesis gas (syngas), H₂ and CO [10] .

Syngas addition can also increase efficiency and reduce emissions while combusting bio-fuels such as bio-oil, ethanol, and bio-gas. It has been shown the addition of 7% H₂ to Jatropha oil for combustion in a 3.7 kW SI engine increased brake thermal efficiency from 27.3% to 29.3%, decreased UHC emissions from 130 to 100 ppm, and decreased CO emissions from 0.26% to 0.17% at maximum power output. Nitric oxide emissions, however, increased from 735 to 875 ppm []. In another study, a 1.6L SI ethanol engine showed an increase in thermal efficiency from 17.21% to 21.65% due to H₂ addition of 6.38% in ethanol. Furthermore, UHC emissions decreased from 1550ppm to 1019 ppm due to 5.49% H₂ addition, and CO emissions decreased from approximately 4050 ppm to 2450 ppm with the addition of 4% H₂, with more H₂ causing an increase in CO emissions. NO_x emissions increased slightly from approximately 30 ppm to 32.5 ppm with the addition of 5% H₂ due to the increased cylinder temperature []. UHC emissions from a spark ignition engine fueled with biogas, composed of primarily CH₄ and CO₂, were reduced from 1530 ppm to 660 ppm with addition of 10% H₂, and the NO_x emissions showed little change []. The discrepancies in NO_x emissions can be attributed to an increase in flame temperature with H₂ injection at a given equivalence ratio, resulting in more thermal NO_x. Conversely, H₂ also enables operation at lean conditions, resulting in lower in-cylinder

temperatures and therefore a NO_x reduction. Overall, these studies show that H_2 or syngas addition in amounts as small as 5-10% improve efficiency and reduce CO and UHC emissions resulting from the combustion of natural gas, diesel, and bio-fuels.

Landfill gas is suitable for the reforming process due to CO_2 and H_2O which are co-reactants to reform CH_4 to H_2 and CO. The basic process is shown in Figure 1.1.

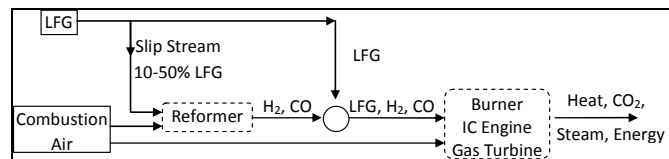

Figure 1.1. Landfill gas reforming and synthesis gas mixing process [11]

A portion of landfill gas is reformed in a catalytic reforming reactor producing syngas and then the syngas is mixed with the unreformed landfill gas. The mixture is mixed with air, and then the final mixture feeds to IC engine or gas turbine.

The addition of syngas, consisting of H_2 and CO, can make LFG fuel much more reactive. H_2 has extremely high laminar flame speed, high flammability limits and low ignition energy caused by its low dissociation energy. Also, CO is not only a highly ignitable gas but also its burning rate is very fast. As a result, the addition of syngas to LFG fuel improves both the chemical and physical processes in combustion, causing more complete combustion than pure LFG allowing more reactive fuel mixture.

1.3. Direct utilization of landfill gas

As mentioned above, there are several suitable technologies for using landfill gas directly. Figure 1.2 shows the landfill gas system where landfill gas is transported from landfill sites to customers. Depending on various factors, such as the presence of existing

energy markets, project costs, the size of the landfill, and potential revenue sources, some recovery and treatment systems may be required for certain landfills.

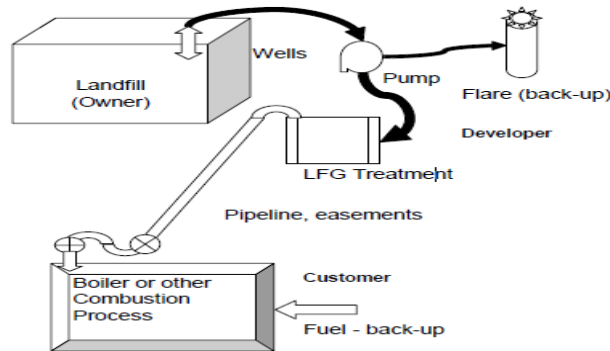

Fig.1.2. Schematic of landfill gas system [12]

1.3.1. Boiler, space heating, and industrial heating

For these applications, very little gas clean-up is required. Systems already operated on natural gas can be fueled with landfill gas with minor modification. In industrial cases, the use of landfill gas as a fuel brings financial advantages due to landfill gas systems' ability to be continuously operated for 24 hours a day, 7 days a week. Space heating applications are seasonal and require high piping costs resulting in consumers needing to live within two miles of landfill site.

1.3.2. Internal combustion engine

Internal combustion (IC) engine technology has been the most widely used approach for generating electricity from landfill gas [13]. This is due to scale, cost and efficiency: IC engines are available in a wide range of sizes so systems can be scaled to match the landfill site; IC engines are a mature technology with a lower cost compared to other technologies; finally, IC engines can provide a higher efficiency than many other technologies. There are also disadvantages to IC engines, primarily high air pollution, especially carbon monoxide

and oxides of nitrogen. Natural gas combustion in IC engines can reach efficiencies of 30%. As landfill gas consists of corrosive elements, special attention is needed to appropriately modify the engine.

1.3.3. Gas turbine

Gas turbines are the second most common type of system used for converting landfill gas to energy conversion even though the number of installations is far lower than internal combustion engines. In spite of the much lower pollutant emissions achieved by gas turbines, compared to internal combustion engines, the number of gas turbine sites have been decreasing due to issues of scale and performance: energetic losses can be severe in small size gas turbines and efficiency is low, especially at low loads [14].

1.3.4. Fuel cell

Fuel cells offer high efficiency, quiet operation, and flexibility of scale (size). However, the cost effectiveness of fuel cells is much lower than other technologies. As costs are reduced and other fundamental issues are resolved, fuel cell technologies may have a more significant role in landfill gas energy conversion applications. A common fuel cell could provide electricity from fully reformed landfill gas, as long as the carbon monoxide is also reduced. Figure 1.3 shows a schematic of a basic fuel cell technology.

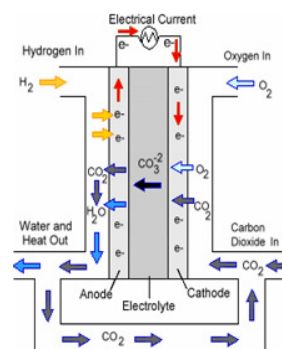

Fig.1.3. Schematic of fuel cell [2]

2. LITERATURE REVIEW

In 1977 Wong studied various mixtures of methane and carbon dioxide as fuels in an internal combustion (IC) single cylinder, four-stroke gasoline engine [15]. The engine was modified for fueling gaseous fuel. Brake horsepower, brake specific fuel consumption, concentrations of unburned hydrocarbon, nitric oxide and carbon monoxide were measured based on fuel quality. At the same engine speed (RPM), as the fuel quality lowered (the fraction of carbon dioxide increased), brake horsepower decreased while brake specific fuel consumption increased. When the fuel quality was lowered, unburned hydrocarbon and carbon monoxide emissions were increased. However, lowering the fuel quality tended to reduce nitric oxide emission.

In 1987 Caterpillar, Inc tested landfill gas operation in its 3516 spark-ignited, turbocharged, separate circuit, aftercooled, 16 cylinder engine 4211 in.³ displacement volume at Waste Management's CID landfill in Calumet City, IL [16]. In the study, the engine was modified for optimizing engine performance to meet the EPA standards for stationary gas engines. Some engine modifications were undertaken including enlarging and increasing the flow capacity, increasing flow pressure regulation and enlarging the fuel piping between the pressure regulator and the carburetor, and the addition of metering valves sized to operate on low-Btu fuel. This engine was not de-rated in spite of the low heating value of the landfill gas. The durability of the engine was demonstrated through 90 days of continuous operation.

In 1995 another engine made by Caterpillar, Inc was developed for landfill gas application [17]. The Caterpillar G3600 spark-ignition engine was developed to demonstrate engine performance and identify any issues caused by the application. Engine performance, exhaust emissions, and fueling system were estimated by simulated landfill gas in the lab and tested through field experiments. The engine durability test was conducted

for 12,000 hours.

Karim and Wierzba examined the mixtures of methane and carbon dioxides as a fuel in 1992 [18]. A single cylinder CFR engine was used for this study. The mean values of the brake power, the concentration of carbon dioxide and unburned methane in the exhaust, and the exhaust gas temperature were measured according to the variation of equivalence ratio. The brake power increased with the increase in equivalence ratio and decreased with carbon dioxide fraction in a fuel. The concentration of carbon dioxide in the exhaust increased with equivalence ratio and the amount of carbon dioxide in a fuel. Unburned methane increased near lean conditions, but sharply decreased at rich conditions. Higher carbon dioxide fraction in a fuel led to higher concentration of unburned methane. The average exhaust gas temperature had the maximum value at the stoichiometric region, and decreased with the volumetric percentage of carbon dioxide.

The evaluation of simulated biogas as a fuel for the spark ignition engine was studied by Huang and Crookes in 1997 [19]. A single-cylinder spark-ignition engine was operated on a simulated mixture fuel consisting of different fractions of natural gas and carbon dioxide with a variable compression ratio. The study covered a wide range of relative air-fuel ratios from lean to rich. The main effect of higher fractions of carbon dioxide was to lower nitrogen oxides while carbon monoxide and total hydrocarbon emissions were increased. At constant speed of 2000rpm and relative air-fuel ratio of 0.98 (fuel rich condition) with changes of CO₂ fraction in the fuel mixture from 23.1% to 41.2%, CO emissions increased from 1.5% to 2.5% and THC emissions also increased from 500ppm to 680ppm, whereas NO_x emissions decreased from 1200ppm to 1000ppm. Brake power also decreased with the presence of carbon dioxide in the fuel mixture from 6.95kW to 6.75kW.

The study conducted by Shrestha and Narayanan in 2007 discussed effective ways for a spark ignition engine to produce power using landfill gas [20]. The engine performance and

combustion characteristics of landfill gas fueled engines were studied by changing spark timing, compression ratio and composition of the landfill gas at different equivalence ratios from lean to rich conditions in comparison to methane operation. Engine performance deteriorated with increasing compression ratio and spark timing. The effects of landfill gas composition were more pronounced at lean and rich mixtures than at stoichiometric mixtures. In addition, the authors also tested the effects of hydrogen addition (up to 30%) to landfill gas. The appropriate amount of added hydrogen improved combustion characteristics and reduced cyclic variations of landfill gas operations at the lean and rich mixtures. For example, 5% added H₂ increased the power of engine from 1.50kW to 1.75kW under 0.6 of equivalence ratio and 600rpm; also, it increased the thermal efficiency from 0.32 to 0.39 at the same condition.

3. EXPERIMENTAL DESIGN

The following experimental work was conducted to evaluate and examine the direct use of landfill gas and the addition of third gas such as hydrogen, carbon monoxide and simulated synthesis gas in a small internal combustion engine in terms of the engine performance and exhaust emissions at different electrical load conditions.

A Honda GC160E-QHA, gasoline (spark ignition) type engine, connected to a small generator was fueled on simulated landfill gas. The engine was modified to allow gaseous fueling. An electric load consisting of sixteen bulbs was constructed for the purpose of providing an easily varied engine load. All gases fed into the engine cylinder such as methane (CH_4), carbon dioxide (CO_2), hydrogen (H_2), carbon monoxide (CO) and air were measured and controlled by rotameters (Fisher & Porter Co.). The electric power generated by the engine-generator system was measured by the WattsUp pro powermeter as an indication of engine load and performance. Exhaust emissions such as carbon monoxide (CO), unburned hydrocarbon (UHC), and oxides of nitrogen (NO_x) as the sum of nitrogen oxide (NO) and nitrogen dioxide (NO_2) were analyzed by an Enerac 700 integrated gas analyzer.

3.1. Engine specification

In this study, the experiments were performed on a Honda 5 hp, 160cc, single cylinder, four-stroke, spark-ignition gasoline engine. The engine picture is shown in Figure 3.1 and the engine specification is given in Table 3.1.



Fig.3.1. Honda GC 160E-QHA engine

Table 3.1. Specification of the tested engine

Length × Width × Height	13.3 × 14.5 × 13.0 in. (337 × 369 × 331 mm)
Dry weight	25.4 lbs (11.5 kg)
Engine type	4-stroke, overhead cam, single cylinder
Displacement [Bore × Stroke]	9.8 cu-in. (160 cm³) [2.5 × 2.0 in. (64 × 50 mm)]
Max. output	4.9 bhp (3.7 kW, 5.0 PS) at 3600 rpm
Max. torque	7.6 lbr ft (10.3 N m, 1.05 kg m) at 2500 rpm
Fuel tank capacity	0.53 US gal (2.0 L)
Fuel consumption	0.51 lb/hph (313 g/kWh, 230 g/PSH)
Cooling system	Forced air
Ignition system	Transistorized magneto
PTO shaft rotation	Counterclockwise
Spark plug gap	0.028 – 0.031 in. (0.70 – 0.80 mm)
Valve clearance (cold)	IN: 0.15 ± 0.04 mm EX: 0.20 ± 0.04 mm

3.2. Engine modification

As mentioned above, the engine's original fueling system is configured for liquid gasoline. Hence, it had to be altered for using gaseous fuels such as methane and propane. The following parts of the engine were removed or modified.

3.2.1. Carburetor, fuel tank, and fuel pump

In gasoline engines, the carburetor blends air and gasoline, and then feeds the engine with the mixture. For the purpose of this study, the carburetor, fuel tank, and fuel pump were detached and removed from the engine. An aluminum plate with a 1/2 inch threaded hole for pipe fitting was fabricated and fixed to the engine in order to directly feed the mixture of fuel and air into the engine cylinder.

Between the plate and cylinder wall, a graphite gasket was installed to prevent the leakage of the fuel and air mixture. Figure 3.2 shows a picture of the modification.

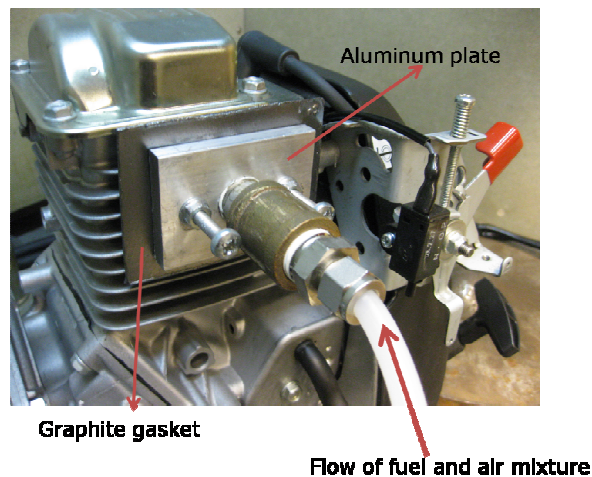

Fig.3.2. Modified cylinder barrel

3.2.2. Air cleaner

This engine's stock configuration used the atmospheric air for oxidants; therefore, it had an air cleaner with a fabric dust filter. However, in order to measure and control the air flow rate, the atmospheric air was not used, instead, laboratory air was used, which is void of dust and other contaminants. Removing the air filter was necessary to avoid fuel/air leakage and ensure precise control and monitoring of fuel/air intake. The air cleaner and filter are shown in Figure 3.3.

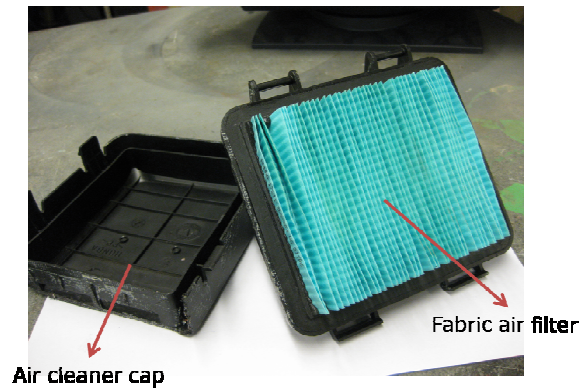

Fig.3.3. Air cleaner detached from the engine

3.2.3. Exhaust

The muffler reduces the noise emitted from the engine. On internal combustion engines, exhaust emissions blow out through the muffler. If the entire exhaust flow is routed into the gas analyzer, it can exceed its safe operating limits and damage it. For this reason only a partial sample of the exhaust flow is drawn off by the analyzer. To facilitate this sampling, the muffler was detached, and a metal plate with a threaded hole was installed on the exhaust outlet. The length of added exhaust pipe was approximately 6 inches long to prevent back pressure. A tee was fitted on the added exhaust pipe so that the analyzer was only drawing off a sample of the exhaust and not receiving the full exhaust flow. This modification is shown in Figure 3.4.

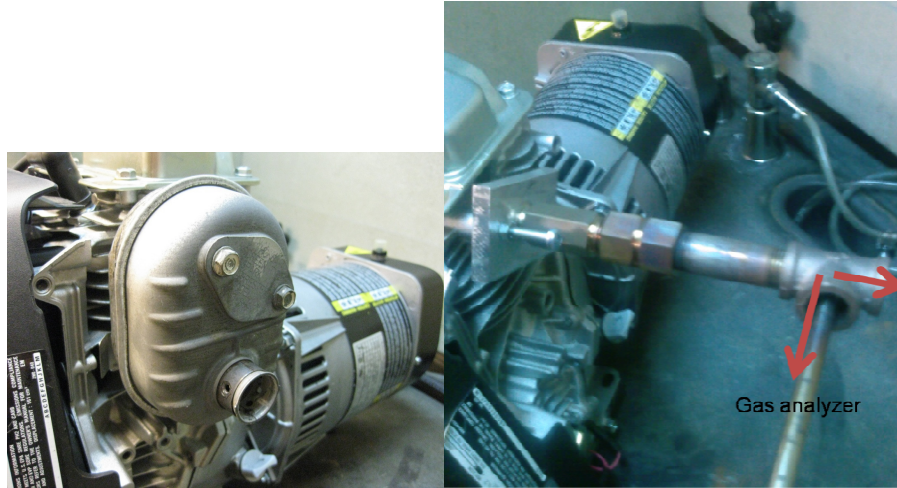

Fig.3.4. (A) Muffler (B) Added exhaust pipe

3.3. Fuel and air supply

3.3.1. Gas flow measurement and control

In the study, four gases were used to create various simulated gaseous fuels: CH₄, CO₂, H₂, and CO. Air was used for oxidants. CH₄, CO₂, H₂ and CO were fed from each gas cylinder (*TechAir*, 99.97%, 99.995%, 99.999%, 99.9%, respectively), and laboratory air was used. The supplied gases were monitored through rotameters made by Fisher & Porter Co., to ensure precise control. Pressure gauges were connected with each in order to accurately calculate mass flow rate of the gases.

A dry gas meter was used to generate calibrations between the actual flow rate and the flow through rotameters. The calibration equations of each gas are provided below.

Table 3.2. Calibration equations of rotameters

Gas	Calibration equation	R ²
CH ₄	$Y = 0.0355X^2 + 0.8578X$	0.9997
CO ₂	$Y = 0.0269X^2 + 0.4441X$	0.9969
H ₂	$Y = 0.0456X^2 + 2.5287X$	0.9993
CO	$Y = 0.0077X^2 + 0.8152X$	0.9999
Air	$Y = 15.436X - 20.392$	0.9995

3.3.2. Fuel mixing

For good engine operation, a homogeneous mixture of fuel and air is required. There were two mixing points where first the CH_4 , CO_2 , H_2 , and CO were mixed and then this mixed fuel and air were mixed. The final mixture flowed into the engine cylinder directly. The mixing system is illustrated in Figure 3.5.

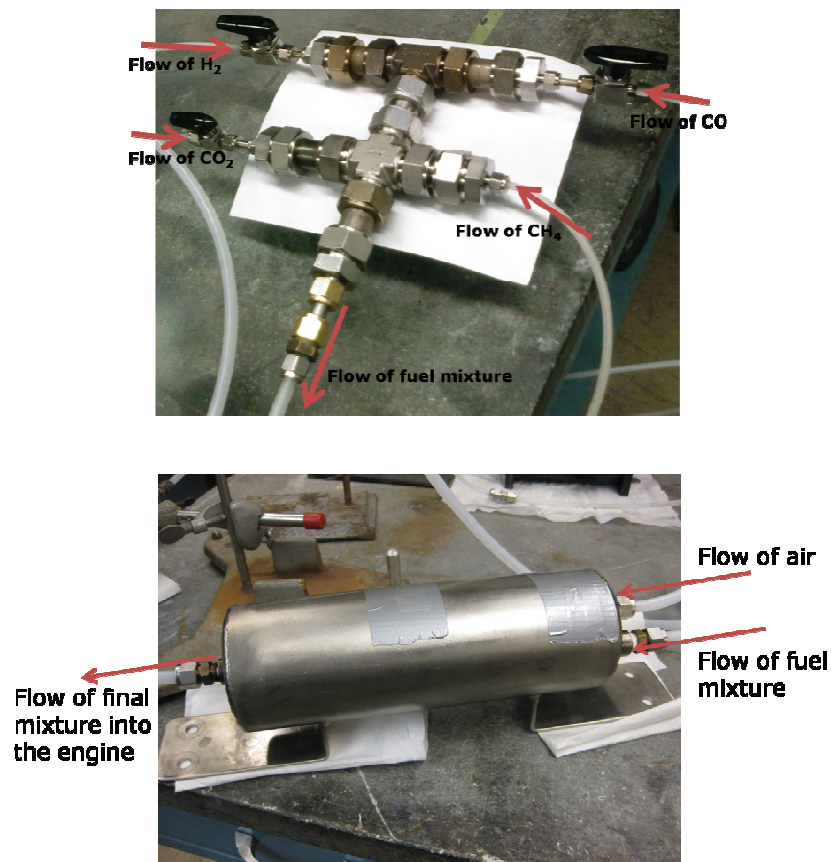

Fig.3.5. Fuel mixing system

3.4. Electrical load

The engine was directly connected to a PRAMAC EG2800 electric generator. This generator and its performance specification are shown in Figure 3.6 and Table 3.3, respectively.

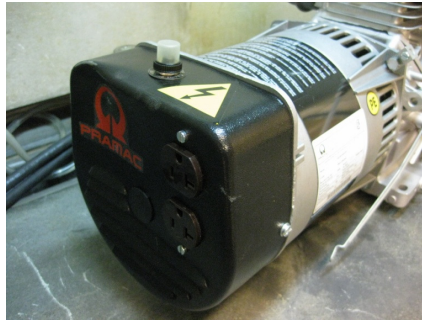
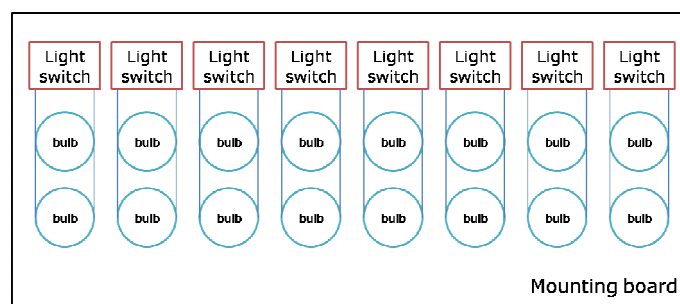

Fig.3.6. PRAMAC EG2800 generator

Table 3.3. Performance specification of the generator

Voltage	120 VAC (single phase)
Continuous Watts	2400 Watts (20 A at 120 V)
Surge Watts	2800 Watts (23 A at 120 VAC)
Receptacle	NEMA 5-20R 125 – 20A

In this test, the term load is used to mean the measured electric power produced by the electric generator. A bank of several light bulbs was used to vary the electric load produced by the generator. To increase the engine loading more bulbs were powered, to decrease the engine load fewer bulbs were powered. This “load board” then consisted of sixteen different light bulbs of 100 – 200 watts each, wired in parallel, with every two bulbs sharing a switch, to allow easy load variation for flexible testing. A block diagram and a picture of the load board are illustrated in Figure 3.7.



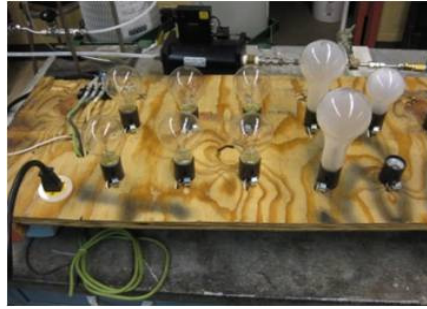

Fig.3.7. (a) Load board block diagram (b) Load board

To measure the power the engine electric generator produced, a Wattsup pro powermeter was used. A current transformer was used to step down the current by a factor of ten so that the meter's current rating was not exceeded. The specification of the meter is presented in Table 3.4. Figure 3.8 and 3.9 shows the powermeter and the circuit diagram between load board and meter, respectively.



Fig.3.8. Wattsup Pro meter

Table 3.4. Technical specification of Wattsup pro powermeter

120 VAC, 60 Hz, 15 amps continuous	
Values measured	True power, voltage, current
Accuracy	± 1.5% + 3 counts

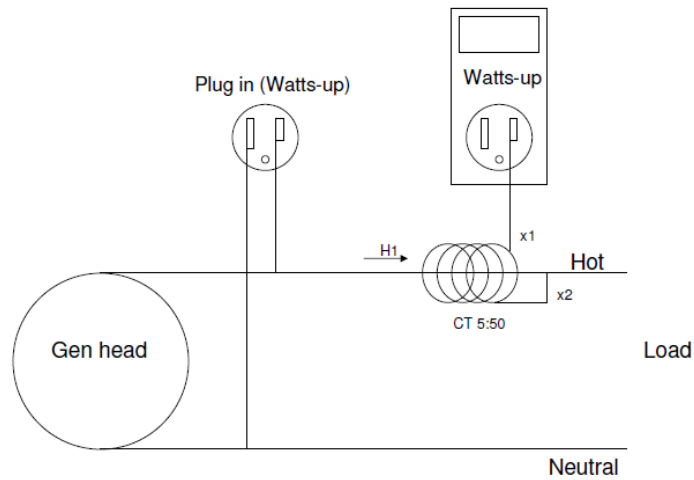

Fig.3.9. Circuit diagram for the meter

3.5. Emission analysis

Emission analysis was conducted with an ENERAC 700, pictured below.



Fig.3.10. ENERAC integrated emissions system Model 700

The instrument's probe was inserted into the exhaust flow as described above. A pump located inside the device would draw a small amount of sample of the stack gas. The sample was conditioned before entering the analyzer, via an onboard water trap. A number

of sensors in the ENERAC 700 analyzed the contents of the stack gas, calculated and displayed the results. Electrochemical (SEM) sensors measured the carbon monoxide, nitric oxide, nitrogen dioxide and oxygen. These SEM sensors consisted of two components: the sensor module and the precision control module (PCM). The function of the PCM is to set the sensitivity of the sensor and also to contain any filter material that removes the effect of interfering gases. Non-dispersive infrared spectroscopy (NDIR) sensors are also included in the ENERAC 700. The NDIR bench operates on the principal that different gases absorb infrared radiation at varying frequencies. The amount of radiation absorbed is measured and used to calculate the concentration of the gas based on Beer's Law. The NDIR bench can measure carbon monoxide, carbon dioxide, and hydrocarbons (as propane). Table 3.5 shows the specification of the gas analyzer.

Table 3.5. Specification of exhaust gas analyzer

Measured parameters	Range	Accuracy
Stack Temp.	0 – 2000°F	2%
O ₂	0 – 25%	0.2%
CO	0 – 2000ppm	2%
CO ₂	0 – 20%	3%
C _x H _y	0 – 2000ppm	3%
NO	0 – 300ppm	2%
NO ₂	0 – 300ppm	2%

Figure 3.11 presents the whole experimental setup.

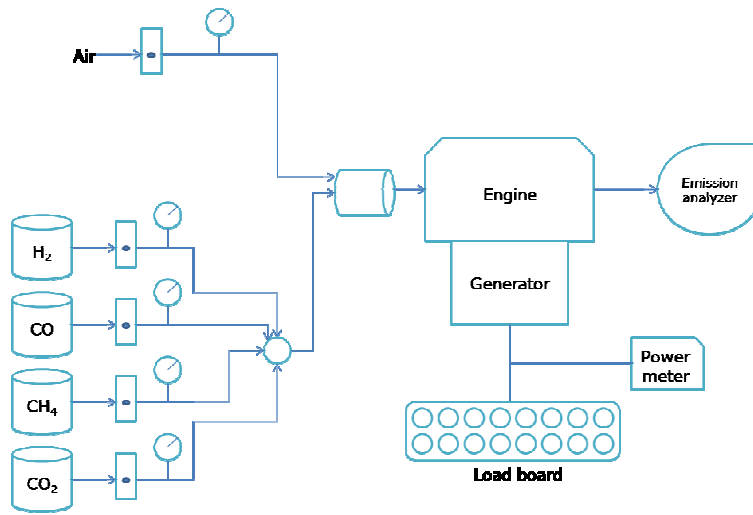

Fig.3.11. Schematic diagram of experimental setup

4. EXPERIMENTAL METHODS

The engine performance and emissions from fueling with CH₄ blended with CO₂ (simulated landfill gas) were evaluated in comparison with pure CH₄ as fuel. A series of experiments were carried out using pure CH₄, and the simulated landfill gas fuels. All the fuels were tested under varying electrical load conditions. The engine was started using CH₄ and it was operated until it reached the steady state condition. The volumetric flow rate of CH₄ and CO₂ gases and the power generated from the engine were measured. Based on the measurements, specific fuel consumption (sfc) and fuel conversion efficiency were calculated. After the engine reached stable working conditions, emission parameters such as CO, CO₂, O₂, HC and NO_x measured by the gas analyzer were recorded. Whenever changing the electrical load, the above stabilization procedure was carried out.

4.1. Detailed procedure

1. The ENERAC 700 was calibrated with 24 hours of each experiment, per the manufacturer's guidelines.
2. Before each test the ENERAC 700 was zeroed for 100 seconds.
3. The ENERAC 700 was connected to a computer to record data.
4. The fume hood in which the engine experiment carried out was turned on.
5. Tube connections from gas sources to each rotameter, from each rotameter to pressure gauges, and to the mixing chamber and engine were closely checked.
6. The air flow was turned on to the engine.
7. The rotameter value for air was monitored and flow was adjusted appropriately.
8. The CH₄ flow was turned on.
9. The rotameter value for CH₄ was monitored and flow was adjusted appropriately.
10. The engine ignition switch was positioned to the 'on' setting.

11. The engine was started.
12. The CO₂ flow was turned on (if required by the specific test).
13. The CO flow was turned on (if required by the specific test).
14. The H₂ flow was turned on (if required by the specific test).
15. The rotameter value for CO₂ was monitored and flow was adjusted appropriately (if required by the specific test).
16. The rotameter value for CO was monitored and flow was adjusted appropriately (if required by the specific test).
17. The rotameter value for H₂ was monitored and flow was adjusted appropriately (if required by the specific test).
18. Bulbs on the load board were turned on.
19. 15 minutes were allowed to pass so that steady state was reached.
20. A probe connected to the gas analyzer was put into the center of exhaust pipe.
21. 10 minutes were allowed to pass until data from the gas analyzer stabilized.
22. Gas analyzer data recording was started on the computer during this 10 minutes.
23. The probe was removed from the exhaust pipe.
24. When the electrical load (and thus the fuel and air flow) was changed, the above procedure was repeated from step 7.
25. Each experiment was repeated three times to calculate the mean values of the experiments.
26. The bulbs on the load board were turned off.
27. The CH₄ flow was turned off.
28. After the engine stopped, CO₂ and air flow were turned off.
29. The engine ignition switch was positioned to the 'off' setting.
30. The ENERAC 700 was allowed to draw in ambient air until all emission values

approached 0 ppm or % (except in the case of air, which was 20.9%).

31. After the test ended, the mass flow meter was turned off.

32. The fume hood was turned off.

33. When all values on the ENERAC 700 reached zero, the device was turned off.

34. It was checked to make sure gas cylinders were completely closed and gas remaining in pipeline was vented.

4.2. Fueling conditions

The different types of simulated fuels were tested for this study. All the gas flow rates were minimum values to generate each power: 0.2kW, 0.4kW, 0.6kW, and 0.8kW. In order to examine the effects of CO₂, tests were conducted with various CO₂ fractions: 15%, 25%, and 50%.

Table 4.1. Landfill gas tests

100% CH ₄					
<i>load [kW]</i>	<i>CH₄ [L/min]</i>	<i>CO₂ [L/min]</i>	<i>CO [L/min]</i>	<i>H₂ [L/min]</i>	<i>air [L/min]</i>
0.2	6.8	0	0	0	100
0.4	7.1	0	0	0	100
0.6	7.3	0	0	0	100
0.8	7.6	0	0	0	100

85% CH ₄ / 15% CO ₂					
<i>load [kW]</i>	<i>CH₄ [L/min]</i>	<i>CO₂ [L/min]</i>	<i>CO [L/min]</i>	<i>H₂ [L/min]</i>	<i>air [L/min]</i>
0.2	6.95	1.2	0	0	100
0.4	7.25	1.28	0	0	100
0.6	7.45	1.3	0	0	100
0.8	7.75	1.35	0	0	100

75% CH4 / 25% CO2					
load [kW]	CH4 [L/min]	CO2 [L/min]	CO [L/min]	H2 [L/min]	air [L/min]
0.2	7.1	2.35	0	0	100
0.4	7.4	2.45	0	0	100
0.6	7.6	2.55	0	0	100
0.8	7.9	2.65	0	0	100

50% CH4 / 50% CO2					
load [kW]	CH4 [L/min]	CO2 [L/min]	CO [L/min]	H2 [L/min]	air [L/min]
0.2	7.7	7.65	0	0	100
0.4	7.95	7.85	0	0	100
0.6	8.25	8.2	0	0	100
0.8	9.55	9.45	0	0	110

A number of experiments were carried out for various operating conditions with H₂, CO, and syngas as additives in the engine fueled with landfill gas consisting of 50% CH₄ and 50% CO₂. 5%, 10%, and 15% of H₂, CO, and syngas were added to the mixture consisting of 50% methane and 50% carbon dioxide. All the added syngas consisted of H₂ and CO, and the fraction of H₂ to CO was two.

Table 4.2. H₂, CO, and syngas addition tests

50% CH4 / 50% CO2 / 5% H2					
load [kW]	CH4 [L/min]	CO2 [L/min]	CO [L/min]	H2 [L/min]	air [L/min]
0.2	6.9	6.8	0	0.72	100
0.4	7.2	7.2	0	0.75	100
0.6	7.6	7.6	0	0.8	100
0.8	8.8	8.8	0	0.9	110

50% CH4 / 50% CO2 / 10% H2					
load [kW]	CH4 [L/min]	CO2 [L/min]	CO [L/min]	H2 [L/min]	air [L/min]
0.2	6.6	6.6	0	1.45	100
0.4	6.75	6.75	0	1.5	100
0.6	7.1	7.1	0	1.6	100
0.8	8.3	8.3	0	1.85	110

50% CH4 / 50% CO2 / 15% H2					
load [kW]	CH4 [L/min]	CO2 [L/min]	CO [L/min]	H2 [L/min]	air [L/min]
0.2	6.35	6.35	0	2.25	100
0.4	6.6	6.6	0	2.35	100
0.6	7	7	0	2.45	100
0.8	8.1	8.1	0	2.85	110

50% CH4 / 50% CO2 / 5% CO					
load [kW]	CH4 [L/min]	CO2 [L/min]	CO [L/min]	H2 [L/min]	air [L/min]
0.2	6.85	6.85	0.72	1.45	100
0.4	7.1	7.1	0.75	1.5	100
0.6	7.55	7.55	0.8	1.6	100
0.8	8.7	8.7	0.92	1.85	110

50% CH4 / 50% CO2 / 10% CO					
load [kW]	CH4 [L/min]	CO2 [L/min]	CO [L/min]	H2 [L/min]	air [L/min]
0.2	6.45	6.45	1.45	2.25	100
0.4	6.75	6.75	1.5	2.35	100
0.6	7	7	1.55	2.45	100
0.8	8.25	8.25	1.82	2.85	110

50% CH4 / 50% CO2 / 15% CO					
load [kW]	CH4 [L/min]	CO2 [L/min]	CO [L/min]	H2 [L/min]	air [L/min]
0.2	6.3	6.3	2.20	1.45	100
0.4	6.65	6.65	2.35	1.5	100
0.6	7	7	2.45	1.6	100
0.8	8.1	8.1	2.85	1.85	110

50% CH4 / 50% CO2 / 5% syngas (H2/CO=2)					
load [kW]	CH4 [L/min]	CO2 [L/min]	CO [L/min]	H2 [L/min]	air [L/min]
0.2	6.65	6.65	0.23	0.46	100
0.4	6.7	6.7	0.23	0.47	100
0.6	7	7	0.25	0.49	100
0.8	8.25	8.25	0.29	0.58	110

50% CH4 / 50% CO2 / 10% syngas (H2/CO=2)					
load [kW]	CH4 [L/min]	CO2 [L/min]	CO [L/min]	H2 [L/min]	air [L/min]
0.2	6.25	6.25	0.45	0.95	100
0.4	6.45	6.45	0.48	0.95	100
0.6	6.8	6.8	0.50	1.01	100
0.8	8	8	0.60	1.20	110

50% CH4 / 50% CO2 / 15% syngas (H2/CO=2)					
load [kW]	CH4 [L/min]	CO2 [L/min]	CO [L/min]	H2 [L/min]	air [L/min]
0.2	8	6	0.71	1.42	100
0.4	6.25	6.25	0.74	1.48	100
0.6	6.6	6.6	0.78	1.56	100
0.8	7.8	7.8	0.82	1.84	110

4.3. Calculations

4.3.1. Engine efficiency (η_f)

The engine efficiency is defined as the ratio of engine power output to the heat release rate of the fuel, as follows:

$$\eta_f = \frac{P}{\dot{m}_f Q_{HV}} = \frac{3600}{sfc Q_{HV}} \dots\dots\dots \text{Eq. (1)}$$

Q_{HV} is the heating value of the fuel [MJ/kg of fuel]. 3600 is a conversion factor. Sfc is the specific fuel consumption, defined as follow:

$$sfc = \frac{\dot{m}_f}{P} \dots\dots\dots \text{Eq. (2)}$$

\dot{m}_f is the mass flow rate of fuel [g/hr], and P is the engine power output [kW]. Thus, the unit of sfc is [g/kWh]. A lower sfc value indicates a lower fuel consumption rate under the same engine power output and higher engine efficiency, implying better fuel economy [21].

4.3.2. Equivalence ratio (Φ)

The equivalence ratio of the burning fuel is one of the most important parameters effecting engine performance. It is defined as follows:

$$\Phi = \frac{(F/A)_{\text{actual}}}{(F/A)_{\text{stoic}}} = \frac{(A/F)_{\text{stoic}}}{(A/F)_{\text{actual}}} \dots\dots\dots \text{Eq. (3)}$$

$(F/A)_{\text{actual}}$ is the actual fuel to air mass ratio, and $(F/A)_{\text{stoic}}$ is the stoichiometric fuel to air mass ratio [21].

4.3.3. Specific emission measure

In some applications, it is useful that emissions are expressed as specific emission measure [g/MJ or lb/mmbtu];

$$\frac{\text{Mass of pollutant } i}{\text{Fuel energy supplied}} = \frac{EI_i}{\Delta h_c} \dots\dots\dots \text{Eq. (4)}$$

EI_i is the emission index for species I [g/kg or g/lb], and Δh_c is the heating value of the supplied fuel [MJ/kg or mmbtu/lb] [21]. EI_i is defined as follows:

$$EI_i = \left(\frac{x_i}{x_{CO} + x_{CO_2}} \right) \left(n \frac{MW_i}{MW_F} \right) \dots\dots\dots \text{Eq. (5)}$$

x_s are mole fractions of each species, and n is the number of carbon in one mole of fuel. MW_i and MW_F are molecular weights of species i and fuel, respectively [22].

5. EXPERIMENTAL RESULTS

Each experiment was repeated three times to calculate the mean values of the experimental data. Graphs of exhaust gas temperature, CO, THC, and NO_x include error bars representing standard deviations.

5.1. Engine efficiency (η_f)

When CO₂ fraction in a mixture of CH₄ and CO₂ increased, η_f decreased. It means more amounts of fuel are needed to generate same power with the increase in CO₂ fraction because the presence of CO₂ in the mixture lowers the combustion enthalpy and the combustion rate of the mixture in a combustion chamber. At 10% H₂ in a fuel, η_f was max as 4.20, 8.09, 11.22, and 12.48% at 0.2, 0.4, 0.6, and 0.8kW, respectively. At 10% CO in a mixture, η_f was max as 4.18, 8.00, 11.27, and 12.43% at 0.2, 0.4, 0.6, and 0.8kW, respectively. Syngas addition also increased the engine efficiency. At 10% syngas in a fuel, η_f was max as 4.24, 8.21, 11.39, and 12.57% at 0.2, 0.4, 0.6, and 0.8kW, respectively. The maximum efficiencies were 0.73% and 1.1% higher than the addition of H₂ and CO, respectively. It means that the use of syngas as an additive can give more efficient engine operation. As electrical load increased, η_f increased, which means the engine has high efficiency with the increase in load. The data shows that the fuel consumption rate increases with more additives, which means that the emission reduction can be achieved by adding H₂ and CO leading to more complete combustion.

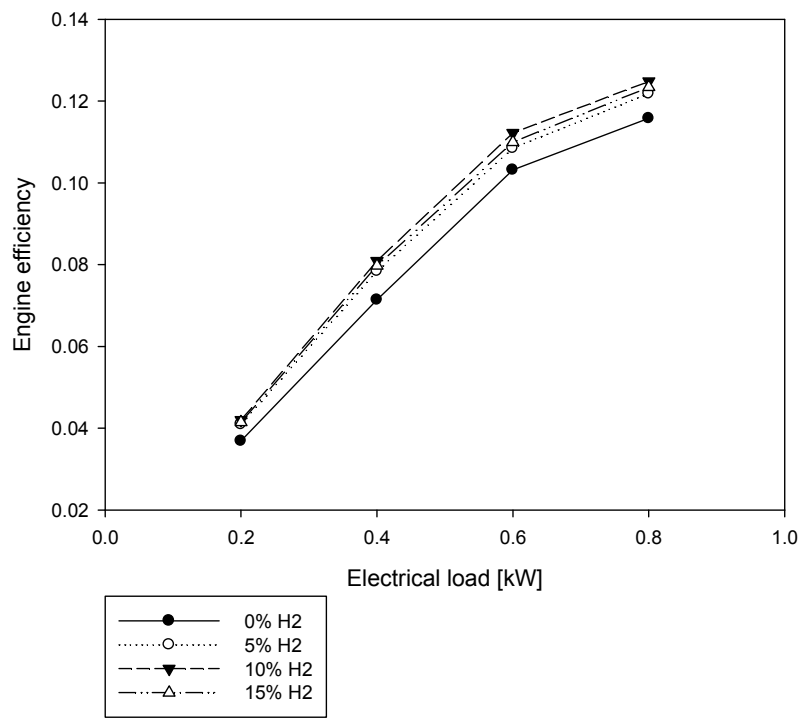
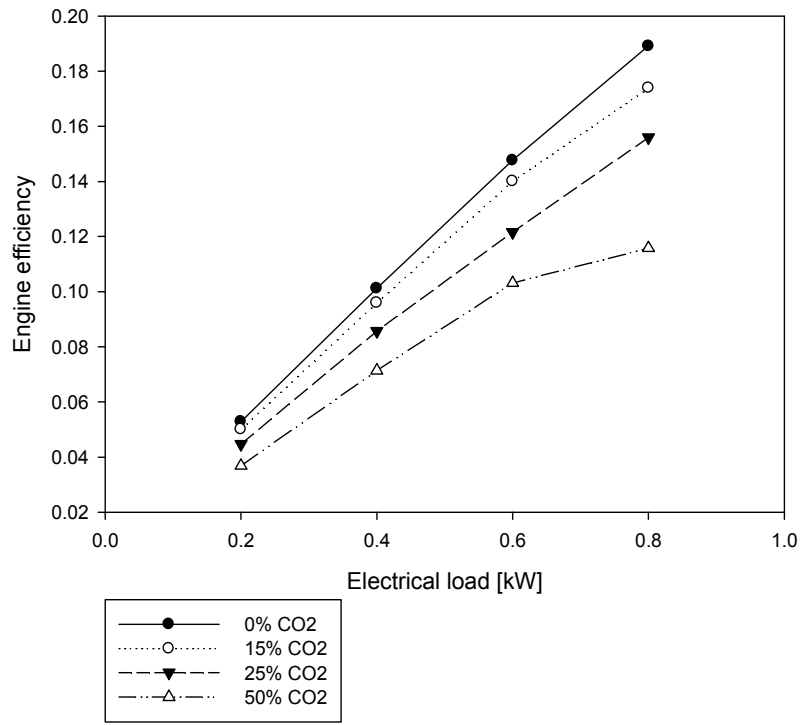

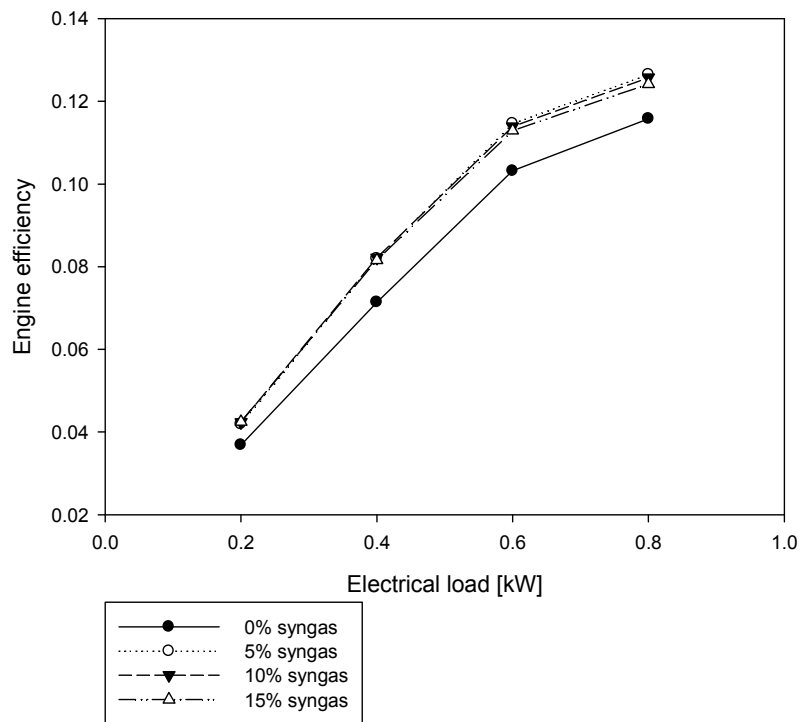
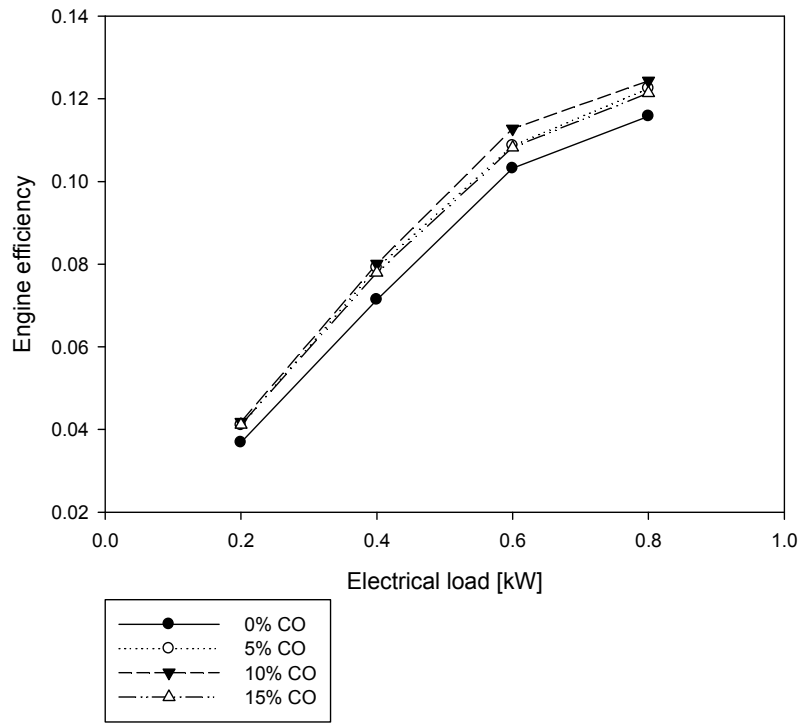
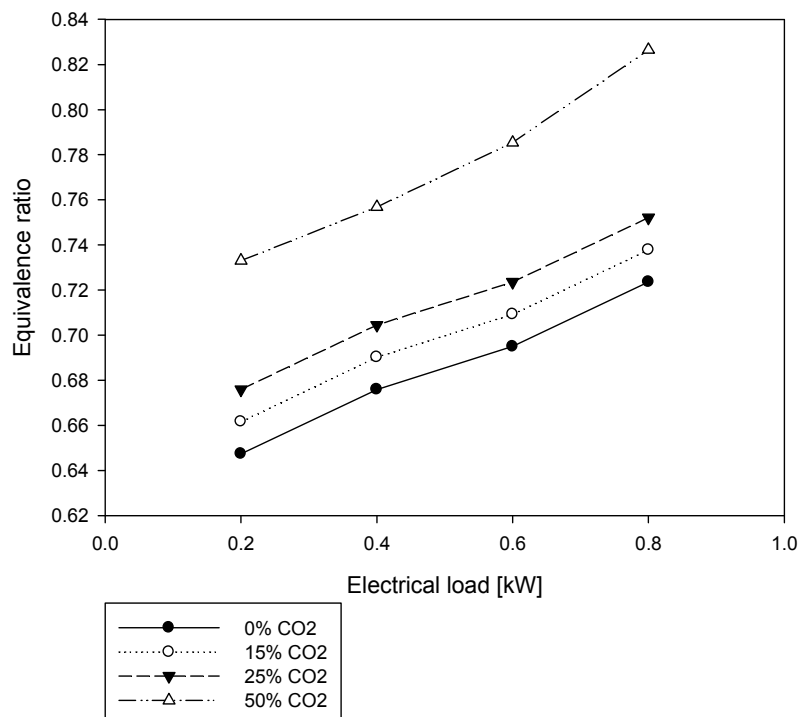
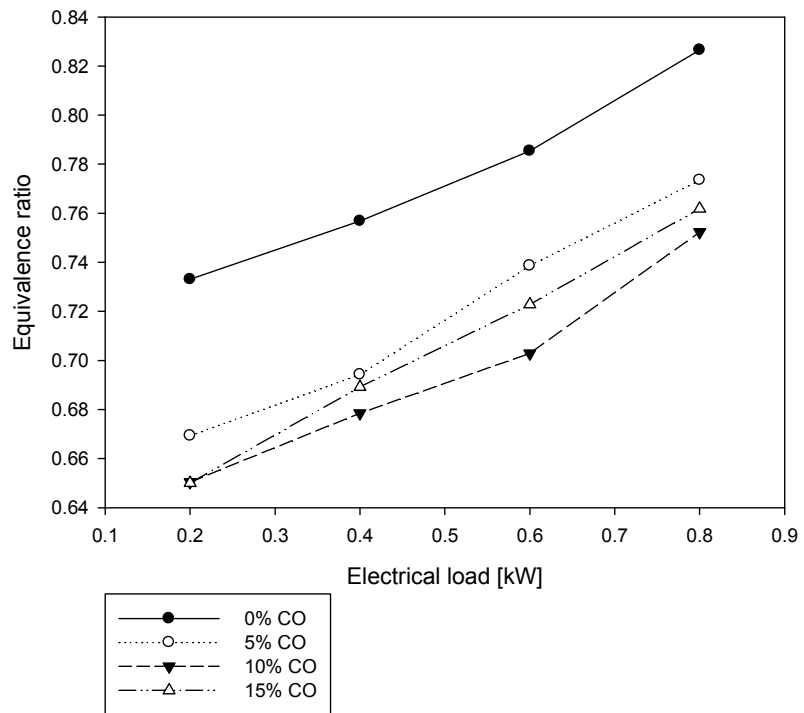
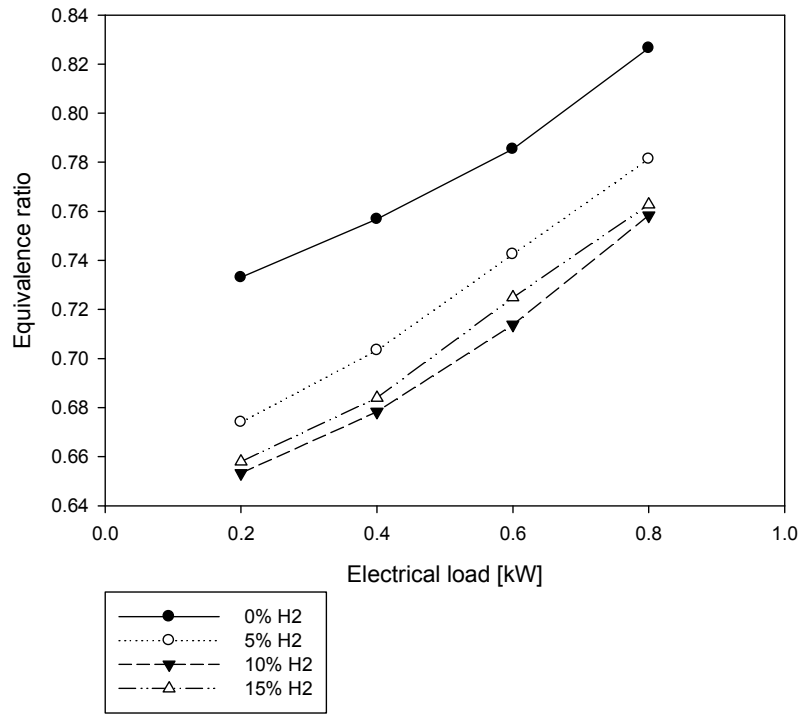

Fig. 5.1. Engine efficiencies with electrical load

5.2. Equivalence ratio (Φ)

In this research, Φ was based on the CH_4 in mixtures. For example, in case of 50% CH_4 / 50% CO_2 fuel mixture at 0.2 kW load, the flow rate of CH_4 and air was 7.7 L/min (with 7.65 L/min CO_2 flow rate) and 100 L/min respectively at 19 psi, so the mass flow rate of CH_4 and air was able to be calculated as 390.74 g/hr and 9197.63 g/hr respectively; thus, the real air/ CH_4 mass ratio was 23.539. Also, the stoichiometric air/ CH_4 mass ratio was calculated as 17.255. Therefore, Φ was 17.255 divided by 23.539: 0.733. The increase of CO_2 content increased Φ . This is because as CO_2 content is high, more fuel is required to generate same power output. The addition of H_2 and CO lowered Φ , and Φ was lowest at 10% H_2 and CO. The addition of syngas drastically lowered ϕ , and ϕ of all fractions of syngas were similar. Φ of syngas added fuels were much lower than H_2 and CO added fuels; for example, at the condition of 10% addition of third gases and 0.2kW load, ϕ decreased by 4% and 0.38% by using syngas instead of using H_2 and CO, respectively. Φ increased with electrical load due to the need of more fuel to produce more power.





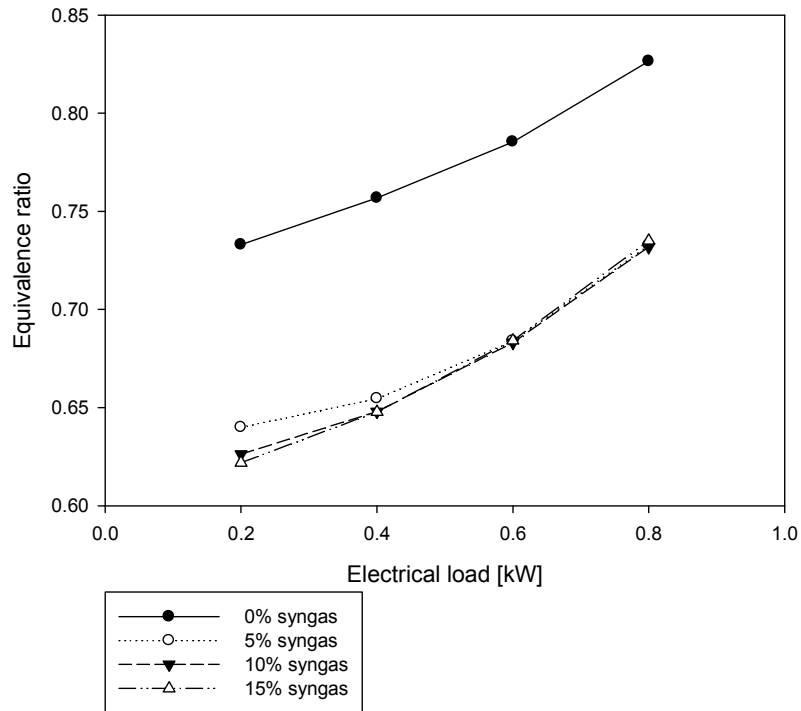

Fig. 5.2. Equivalence ratio with electrical load

5.3. Adiabatic flame temperature

The temperature at which combustion occurs is a primary consideration to determine emission production from combustion engines. However, it is impossible to measure temperature in engine cylinder without extreme modification of engine which can effect on engine performance. Thus, the adiabatic flame temperature was calculated, based on the inlet composition, the outlet composition, and the total flow rate adjusted for each composition to obtain same engine load. Figure 5.3 shows the results of those calculations as a function of engine load.

As electrical load increased, the adiabatic flame temperature increased. However, the flame temperature was nearly constant for the gas mixtures with 0 to 25% CO₂ contents. The mixture with 50% CO₂ had a slightly lower flame temperature at 0.4kW load: about 23°C less than other mixtures. This indicates that changes in emissions can be attributed

to impacts of gas mixture composition and the resulting chemistry of combustion rather than temperature effects whereas for the mixture containing 50% CO₂ the flame temperature had a small effect on emission production.

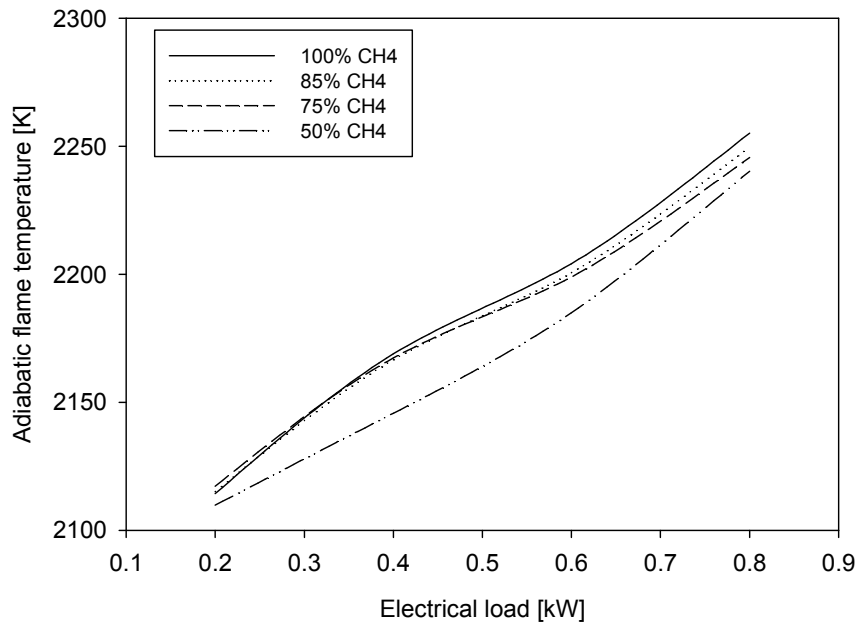
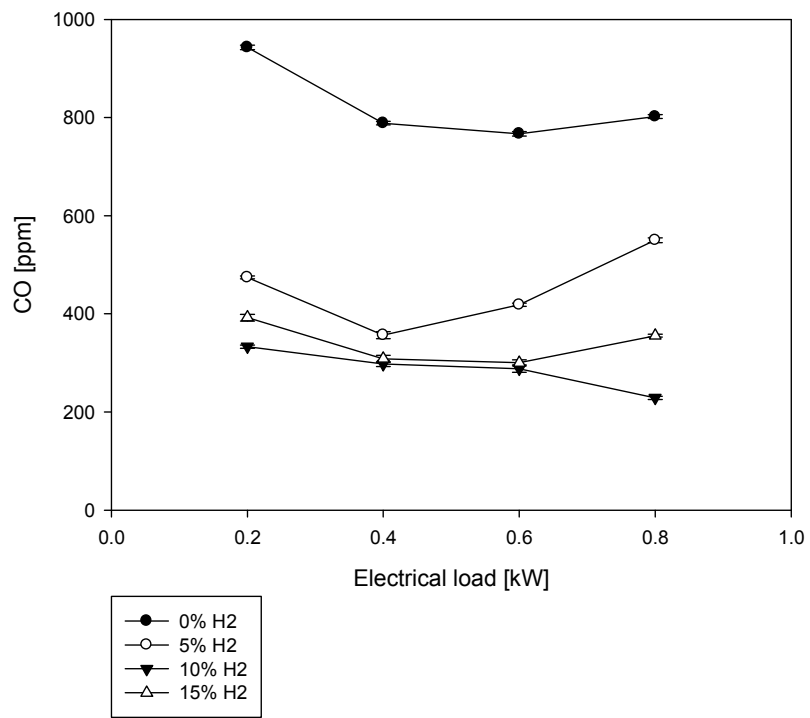
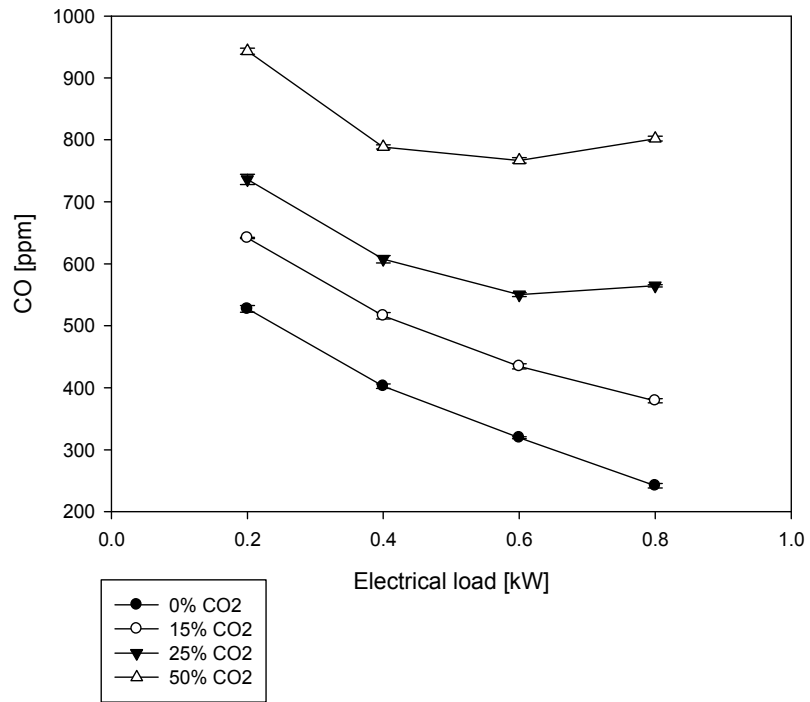

Fig. 5.3. Adiabatic flame temperature with electrical load

5.4. Carbon monoxide (CO)

In the operation with CO₂ addition, CO emissions usually increased at all load conditions because of the need of more amount of CH₄ to generate same power and lower engine efficiency with higher CO₂ fraction. For example, the CO concentrations at 0.4kW load using 15% CO₂, 25% CO₂, and 50% CO₂ were increased by 22.04%, 33.73%, and 48.96%, respectively in comparison to pure CH₄. With increasing load, CO emissions decreased until 0.6kW load, but the CO emissions of 25% CO₂ and 50% CO₂ blends increased at 0.8kW. This may be related to engine efficiency and the CH₄ flowed to the engine cylinder. As load increased, engine efficiency increased leading better combustion so that CO emissions decreased. At 0.8kW load of 25% and 50% CO₂ blends, however,

much amount of CH₄ entered to the engine than 15% CO₂ mixture and pure CH₄, so CO increased in spite of better combustion. H₂ addition reduced CO emissions of landfill gas. This may be because H₂ produces only H₂O as a combustion product and its high ignitability. The 10% H₂ mixture emitted the lowest CO at all load conditions. CO emissions decreased with loads until 0.4 or 0.6kW; however, increased again at 0.8kW load except the 10% H₂ blend which decreased with increasing loads. CO addition also reduced CO emissions of landfill gas. The fuel containing 10% CO emitted the lowest CO. While the CO emission of 10% CO added fuel decreased with loads, 5% and 15% CO contained fuels had the lowest CO emissions at 0.4kW load. This may be explained by engine efficiency and CO's fast combustion rate. At 10% CO, engine efficiency was highest; also, when much more CO entered to an engine cylinder, the unreacted CO with the CO as a combustion product could emit from the engine cylinder. Syngas addition remarkably reduced CO emissions of landfill gas. At 0.2 and 0.4 kW loads, 10% syngas added landfill gas emitted the lowest CO as 303.4 and 230.1ppm. CO emissions at 0.6 and 0.8kW loads were lowest: 227.6 and 203.1ppm each when 5% syngas was added. As mentioned above, because of high laminar flame speed and low ignition energy of H₂ and fast burning rate of CO, the addition of syngas to LFG changes chemical and physical processes in combustion, which results in more reactive fuel mixture. CO emissions slightly decreased with the increase in electrical load.



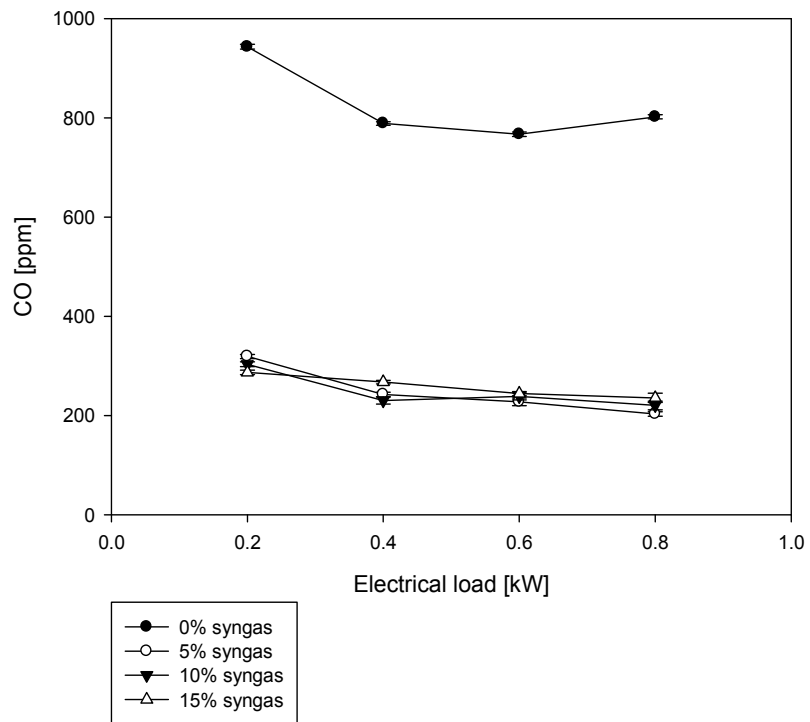
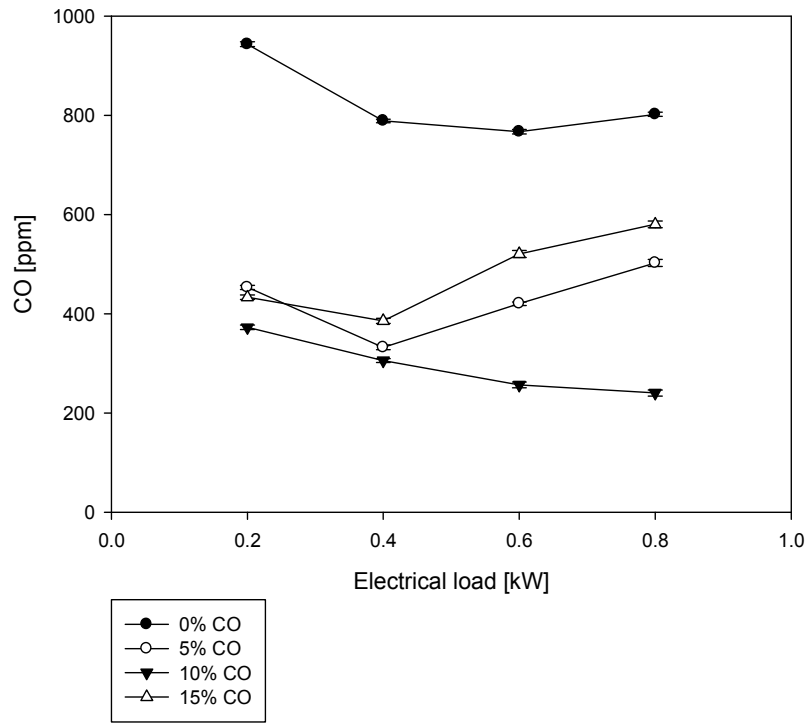
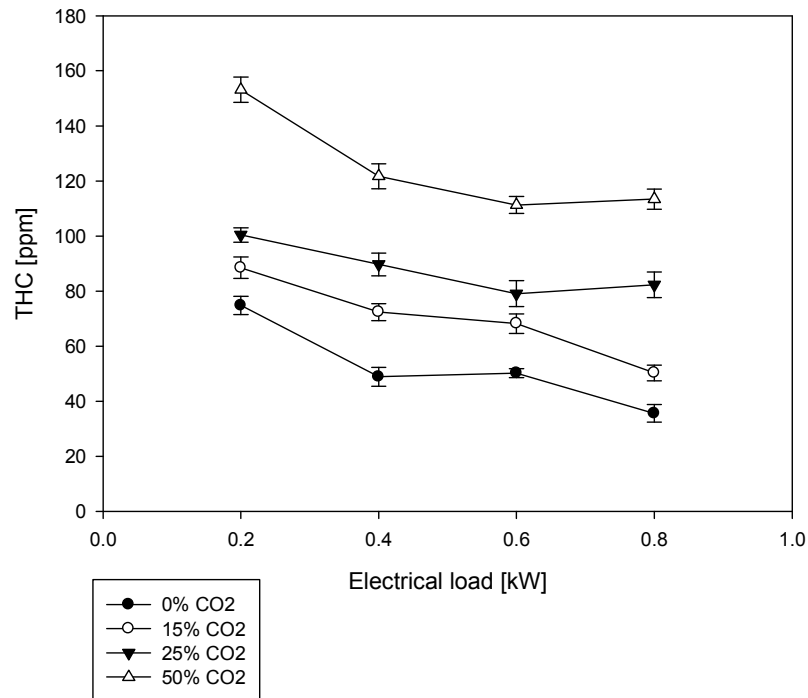
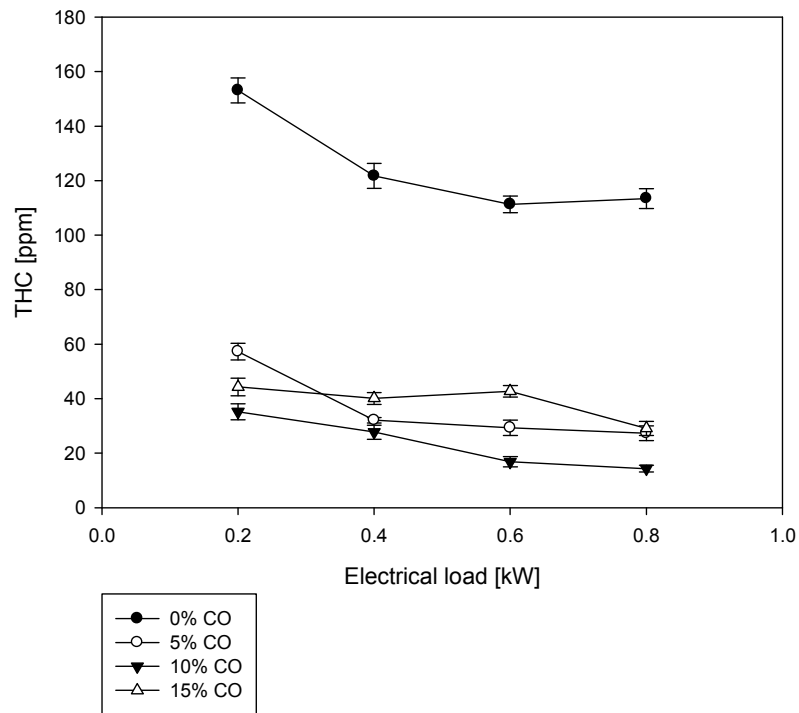
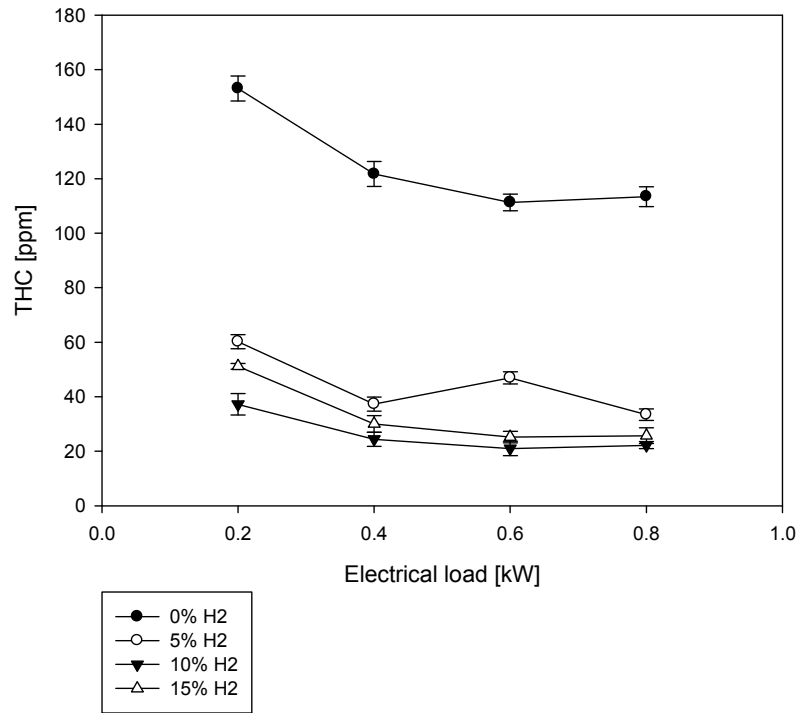

Fig. 5.4. CO emissions with electrical load

5.5. Total hydrocarbon (THC)

THC emissions had similar tendencies to CO emissions. The THC emissions increased with CO₂ percentages in mixtures, and decreased with electrical load. High CO₂ fraction in a fuel leads worse combustion in the engine cylinder, and the engine efficiency increased with electrical load. Also, between 0.6 and 0.8kW load conditions, the THC emissions of 25% and 50% CO₂ blends increased despite increase in load. It can be explained by the same reason with the case of CO emissions: much more amount of CH₄ entered to the engine. The 10% H₂ mixture emitted the lowest THC. At 0.6kW load, 0%, 10% and 15% H₂ added fuels emitted lower THC than other loads except the fuel 5% H₂ added: lowest THC at 0.8kW load. The 10% CO mixture emitted the lowest THC. At 0.8kW load, CO added fuels emitted lower THC than other loads. It means when using CO added fuels, higher load leads better combustion. THC emissions of the syngas added landfill gas had similar trends to CO emissions.





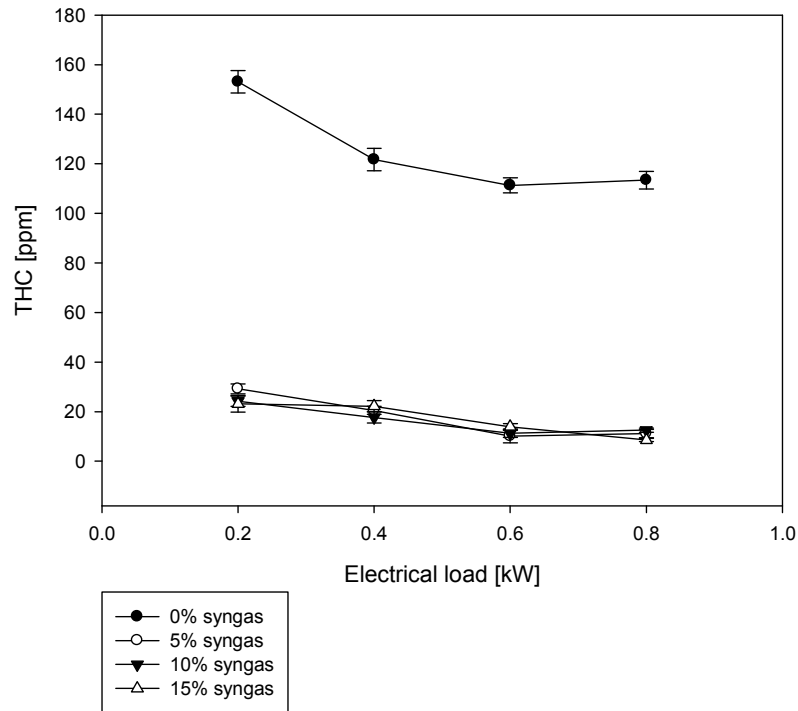

Fig. 5.5. THC emissions with electrical load

5.6. Oxides of nitrogen (NO_x)

There are three major NO_x formation mechanisms: Zeldovich mechanism, Fenimore mechanism and NO_x from fuel. The fuel mixture contained no nitrogen component, so NO_x emissions here were not from fuel (also the fuel mixture did not contain any contaminants such as H_2S , so SO_x emission were not produced). Zeldovich mechanism is that high temperature causes nitrogen from the air to dissociate into nitrogen radicals which react with oxygen to form NO . Some of NO is converted to NO_2 when further reactions occur in the combustion chamber and downstream in the exhaust. This mechanism is not significant below 1800K. Under Fenimore mechanism called prompt NO_x fuel radicals such as CH_3 react with N_2 from the air to form CHN molecule and nitrogen radical. This nitrogen radical reacts with oxygen to form NO . Other possible mechanism is N_2 reacts with oxygen radical to form N_2O , and it can become to NO and contribute in NO to NO_2

mechanism in the system.

Temperatures above 1800K cause the diatomic nitrogen to dissociate forming nitrogen radicals. While CO₂ addition does decrease the nitrogen radical concentration, since the nitrogen concentration in the system is high, the addition of CO₂ does not significantly impact the nitrogen content. The CO may engage in a CO + N route to form CON, which upon further reaction forms CO₂ and N₂, effectively preventing the N₂ radicals from forming CHN radicals.

NO_x emissions slightly decreased with increase in CO₂ fraction while increased with electrical load. NO_x formation is directly related to the flame temperature in an engine cylinder. From 0% to 50% of CO₂ in fuels, the NO_x emissions decreased by 12.4, 8, 10.1, and 26.9ppm at 0.2, 0.4, 0.6, and 0.8kW, respectively. It means that the presence of CO₂ in fuel mixtures lowered the flame temperature. The reason why NO_x decreased with loads is due to the need of more fuel to generate more power leading higher flame temperature in a combustion chamber. In general, NO_x was reduced by adding H₂ in fuels. This is attributed to H₂ addition allowing the lean-burn combustion leading to cool combustion. NO_x was lowest at 10% H₂, and increased with the increase in electrical load because with loads the flame temperature in the engine cylinder increased to take up the additional loading. NO_x was lowest at 10% CO which means CO can allow cool combustion in an engine cylinder as similar as H₂. CO emissions increased with the increase in electrical load because with loads the flame temperature in the engine cylinder increased to take up the additional loading. The addition of syngas significantly decreased NO_x emissions. At each load condition, 5% syngas made NO_x emissions lowest. Because of the fact that higher load requires more fuel, NO_x emissions increased with increasing load. Also, the addition of syngas allowed more stable combustion of the fuel at lower temperature.

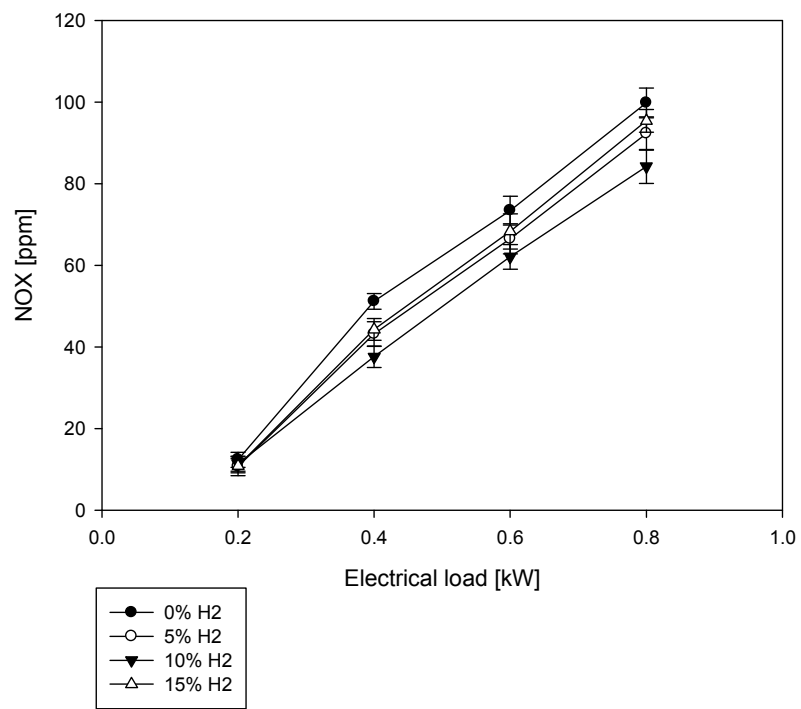
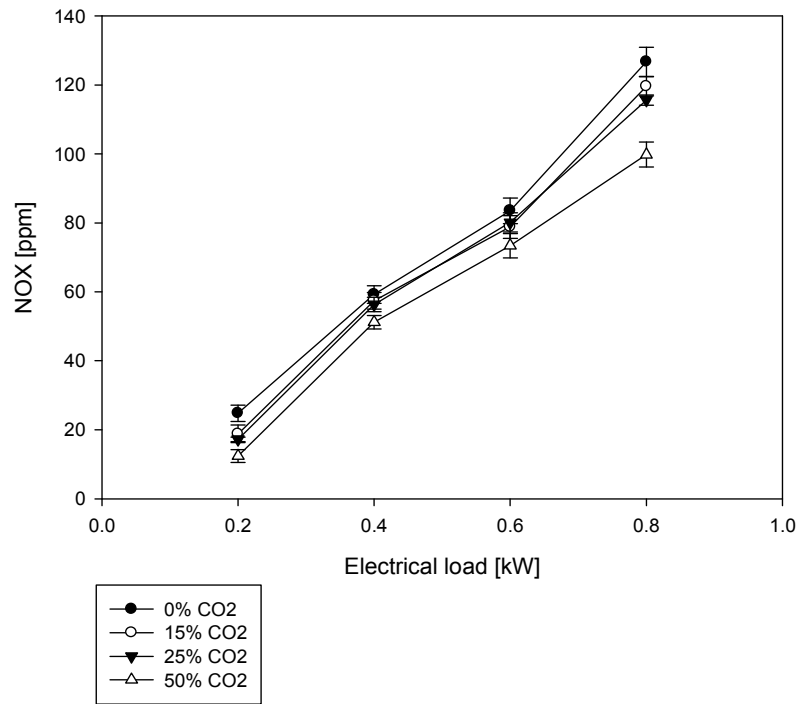

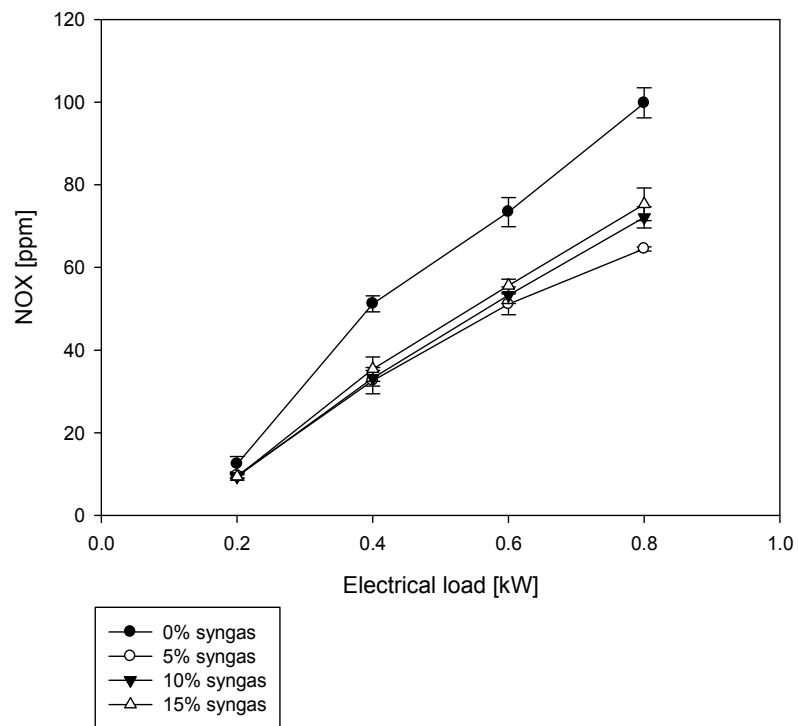
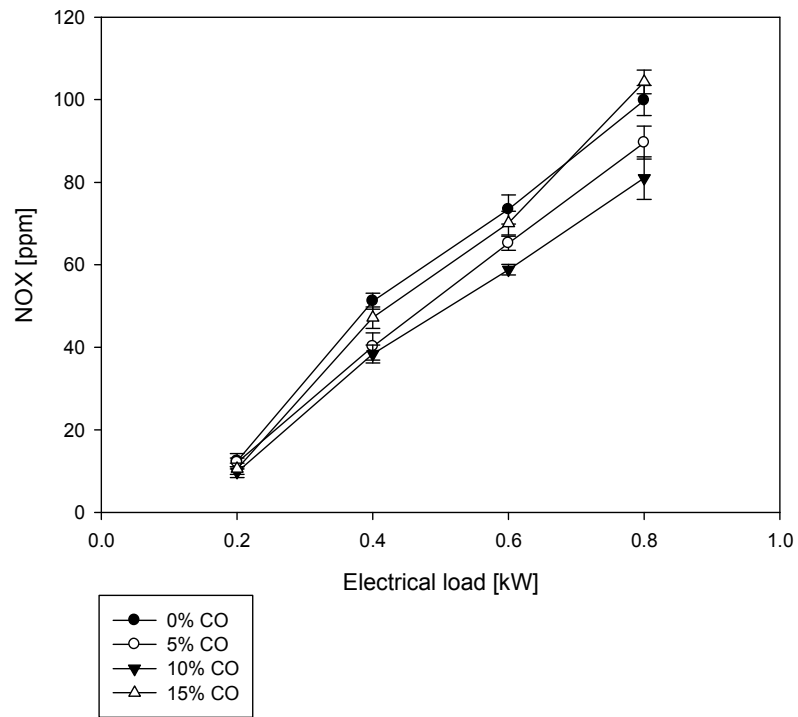

Fig. 5.6. NO_x emissions with electrical load

6. COMPARISON TO REAL FIELD COMBUSTION SYSTEMS

In order to examine the effectiveness of the study, the engine used for the test was compared to other large and real field engines and/or turbines in terms of emissions. Other engines (and/or turbines)' emissions were measured and rated by manufacturers, and carbon monoxide, total hydrocarbon and oxides of nitrogen were compared [2]. Emissions from the tested engine in this research were taken at maximum load condition (0.8 kW power output) when using 50% CH₄ and 50% CO₂ as a fuel. Caterpillar G3516 LE four-stroke internal combustion reciprocating engine, Solar Centaur 40 gas turbine, Capstone C200 microturbine were selected for comparison [2]. Figure 6.1 shows emissions from these three systems and the tested engine in the study.

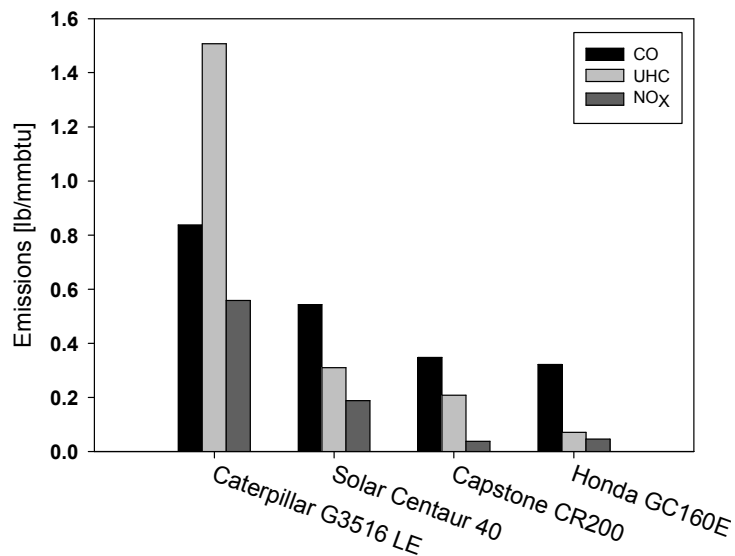

Fig. 6.1. Emissions of four different combustion systems

Caterpillar G3516 LE engine emitted the highest CO, THC and NO_x. NO_x emission was almost 3 times, 14.5 times and 14 times as high as Solar Centaur 40 turbine, Capstone CR 200 microturbine and Honda GC160E engine, respectively. CO was the highest value in all technologies' emissions except Caterpillar G3516 LE engine. Particularly CO

emissions ranged from 0.38 to 0.65 times the emission of Caterpillar G3516 LE engine. Caterpillar G3516 LE engine had remarkably high THC emission. The difference between maximum THC value and minimum one was approximately 1.439 lb/mmbtu.

7. CONCLUSIONS

The presence of CO₂ in fuel mixtures deteriorated the engine performance and produced more pollutants in emissions than pure CH₄. Engine efficiency was decreased by mixing with CO₂ at same load conditions. As CO₂ fraction in a fuel increased, the equivalence ratio increased, which means more fuel was needed to generate same power output. NO_x slightly decreased whereas CO and THC increased with CO₂ fraction. Also, according to the increase in electrical engine load, engine efficiency and CO and THC emissions were lowered, which means higher engine load leads better combustion.

The mixture of simulated landfill gas consisting of 50% CH₄ and 50% CO₂ and H₂, CO and simulated synthesis gas consisting of H₂ and CO (H₂/CO = 2) were also tested for the IC engine. These three gases (H₂, CO, and syngas) were added up to 15% to the fuel mixtures. These three gases not only lowered all emissions (CO, THC, and NO_x) but also improved engine efficiency. However, when the fractions of H₂, CO, and syngas in landfill gas fuel mixtures exceeded appropriate points, engine efficiency decreased and pollutant emissions increased; 10% was the most suitable fraction. Of these three gases: H₂, CO, and syngas, syngas most effectively improved engine efficiency, and reduced pollutant emissions: CO, THC, and NO_x.

As a future work, it can be done to measure the portion of CH₄ in THC emissions by using more sensitive analyzer such as micro GC. This work will allow finding a conversion of fuel mixture leading to more detailed analysis for the production of emissions.

REFERENCES

- [1] EIA International Energy Outlook 2010, <http://www.eia.doe.gov/oiaf/ieo/highlights.html>
- [2] Westby, K.J.; Castaldi, M.J., A Comparison of Landfill Gas to Energy Technologies, IT3 #120, 2008
- [3] Themelis, N.J.; Ulloa, P., Methane Generation in Landfills, *Renewable Energy*, 32 (2007), pp. 1243-1257
- [4] Themelis, N.J., The environmental impacts: Assessing waste-to-energy and landfilling in the US, *Waste Management World*, 2002, pp. 35-41
- [5] <http://msw.cecs.ucf.edu/Gas.ppt>
- [6] EPA, Landfill Methane Outreach Program, 2006
- [7] <http://www.eia.doe.gov/>
- [8] Susan A. Thorneloe, Landfill gas utilization – options, benefits and barriers, In: The US conference on MSWM, 1992
- [9] <http://www.ventureengr.com/blog/2009/01/high-btu-gas-plant-landfill-gas-processing>
- [10] Kohn, M.P.; Castaldi, M.J.; Farrauto, R. J., Auto-thermal and dry reforming of landfill gas over a Rh/Al₂O₃ monolith catalyst, *Appl. Catal. B: Environmental*, 94 (2010), pp. 125-133
- [11] Kohn, M. P.; Lee, J.; Basinger, M. L.; Castaldi, M. J., Performance of an Internal Combustion Engine Operating on Landfill Gas and the Effect of Syngas Addition, *Ind. Eng. Chem. Res.*, 2011, 50 (6), pp. 3570-3579
- [12] www.epa.gov/climateleaders/documents/events/may2005/hildreth0505.pdf
- [13] http://en.wikipedia.org/wiki/Landfill_gas_utilization
- [14] Bove, R.; Lunghi, P., Electric Power Generation from Landfill Gas using Traditional and Innovative Technologies, *Energy Conversion and Management*, 47 (2006), pp. 1391-1401
- [15] Wong, J. K. S., Study of mixtures of methane and carbon dioxide as fuels in a single

cylinder engine (CLR), SAE reprints, 1977, No. 770796, p. 12

[16] Marcari, N. C.; Richardson, R. D., Operation of a caterpillar 3516 spark-ignited engine on low-btu fuel, *Trans. ASME J. Engineering for Gas Turbines and Power*, 1987, **109**(4), pp. 443–447

[17] Mueller, G. P., Landfill gas application development of the caterpillar G3600 spark-ignited gas engine, *Trans. ASME J. Engineering for Gas Turbines and Power*, 1995, **117**(4), pp. 820–825

[18] Karim, G. A.; Wierzba, I., Methane–carbon dioxide mixtures as a fuel, SAE Special Publications, 1992, No.927, No 921557, pp. 81–91

[19] Huang, J.; Crookes, R.J., Assessment of simulated biogas as a fuel for the spark ignition engine, *Fuel*, 1998, Vol.77, No.15, pp. 1793-1801

[20] Shrestha, S.O.; Narayanan, G., Landfill gas with hydrogen addition – A fuel for SI engines, *Fuel*, 87 (2008) 3616-3626

[21] Heywood, J.B., *Internal combustion engine fundamentals*, New York: McGraw-Hill; 1988

[22] Turns, S.R., *An introduction to combustion: concepts and applications*, 2nd edition, McGraw-Hill; 2000