

# MATERIAL RECOVERY DESIGN OF OCEAN COUNTY, NEW JERSEY

**ERNEST J. ROMEO JR.**

RRT Design & Construction Corp.

A Subsidiary of Resource Recycling Technologies, Inc.  
Melville, New York

## ABSTRACT

This paper reviews the design approach for material recovery systems, which, through balancing a combination of manual and mechanical sorting techniques, is able to automatically sort up to 75% of incoming material and process to market specifications while also achieving a percentage of residue less than 5%.

The system is designed utilizing a two-stream approach of processing paper and commingled containers separately to maximize material recovery utilizing engineering expertise which integrates state-of-the-art technology to separate and process recyclable material.

The technologies applied include the customized use of various material handling conveyors, electromagnets, eddy current separators, air classifiers, vibratory screens and feeders, mechanical sorting tables, crushers, densifiers, balers, trommel screens, and dust collection equipment.

## NOMENCLATURE

### Aluminum

UBC = Aluminum Used Beverage Containers.

Cullet = Used glass that has been crushed and is free of contaminants such as caps, rings, enclosures, and other contaminants and can be sent directly to a glass furnace.

HDPE = High Density Polyethylene.

MRF = Material Recovery Facility.

### Negative

Sorting = To be processed by exception, material which remains on a conveyor belt after removing all other items.

ONP = Old Newsprint.

OCC = Old Corrugated Containers.

PET = Polyethylene Terephthalate.

PLC = Programmable Logic Control.

### Positive

Sorting = Manually or physically removing items from a stream of material on a conveyor belt.

Residue = Contaminants removed during inspections and nonrecyclable by-product of the processing system.

TPD = Tons Per Day.

## OVERVIEW

With limited land availability and the emphasis on environmental safety, today's solid waste disposal solutions continue to change whereby more emphasis is being placed on recycling as the solution for the future. The EPA has set a guideline for local governments to recycle 25% of solid waste by 1992, with some states long range recycling goals set as high as 50% by as early as 1994 [1]. To attain these goals, municipalities

and private entrepreneurs have sought full-service contracts for recycling systems.

In general, Material Recovery Facilities (MRFs) should be designed with four principal functional considerations in mind: receiving, processing, product storage, and shipping [2]. Each of these functions can be related to the three main components of MRF design.

- (a) Facility.
- (b) Equipment.
- (c) Marketing.

Receiving and product storage are functions of the facility and its design. Facility considerations should include: location and proximity to major roadways, tipping area for maneuvering trucks and storing incoming product, traffic flow queuing and scaling, tipping height for accommodating various truck styles, finished goods storage space, and shipping docks and loadout areas. Shipping of finished goods, which are considered raw material feedstock for other industries, is a function of both facility design and marketing. Both must interface to obtain a good design and should consider: the number of docks, rolling stock requirements, type of loadout vehicle, distance to market, loadout scheduling, and need for covered storage areas for bulk materials.

The last of our three main components is equipment which relates closely to the processing function. The process technology has to integrate with the facility and marketing to form a complete system design. The inherent advantage of full-service contracting is in the ability to interface each of the three main functions of a MRF together in a manner that best utilizes space and labor to minimize overall facility costs and maximize marketing revenues. These components help form the overall objective of a MRF; to cost effectively convert selected post-consumer and post-industrial solid waste into marketable scrap.

The first step in MRF design is understanding material input, which is made up of three key factors: composition, density, and volume. Waste streams and compositions do vary widely, depending on factors such as seasonality or residential and commercial mix. Commingled recyclables is no exception; experiences encompassing recycling plants in five states show significant variations in recyclables composition. Some variances are attributable to factors such as bottle bill legislation and seasonal populations. These ranges are summarized in Table 1.

In addition to variations in the recyclable streams, each component can have a wide spectrum of densities, as shown in Table 2. Material received in both whole and flattened states further compounds the effects of size and weight on design and equipment selection. In

TABLE 1 MATERIAL COMPOSITION

Product	High	Low	Avg
Received	%	%	%
Mixed Paper	31.1	0.8	9.7
OCC	16.9	1.7	9.0
ONP	75.4	11.0	50.6
Glass	33.6	14.3	24.7
Tin	7.6	2.1	4.5
Plastic	6.9	0.5	2.6
Aluminum	3.6	1.6	2.5

summary, product mix plays a significant role in facility sizing and MRF design.

Incoming material must be processed at sufficient quality to meet marketing objectives. Quality control and product specifications must be considered. Each end product is a raw material feedstock for another industry and must conform to certain standards and specifications.

This paper's primary focus is on equipment selection and processing recyclables at the Ocean County Materials Recovery Facility. The design and equipment selection was based on the following fundamental principles:

- (a) Productivity throughput.
- (b) Quality of finished goods.
- (c) Space conservation.
- (d) Safety and health.
- (e) Maintenance and reliability.
- (f) Redundancy and flexibility.

### Ocean County

The Ocean County Recyclable Materials Processing Facility is located in Lakewood Township, Ocean County, New Jersey. The project was initiated in 1989 as a result of the New Jersey Mandatory Statewide Source Separation Act of 1987. The facility receives materials in a two stream approach, paper and commingled containers. Ocean County is a popular resort area centrally located on the New Jersey shore between New York City, Philadelphia, and Atlantic City and was regionally designed to serve 33 municipalities. Ocean County has a large retirement community, where ap-

**TABLE 2 POST CONSUMER MATERIAL DENSITIES  
(As Received)**

<u>Paper:</u>	<u>Typical Densities</u>
Newspaper	475 lb/cu yd
Corrugated	350 lb/cu yd
High Grades	300-400 lb/cu yd
<u>Glass:</u>	
Whole Bottles:	
Clear	500 lb/cu yd
Green or Amber	550 lb/cu yd
Crushed Glass:	
Semi-Crushed	1000 lb/cu yd
1-1/2" Mechanically Crushed	1800 lb/cu yd
1/4" Furnace Ready	2700 lb/cu yd
<u>Aluminum:</u>	
Whole	50 lb/cu yd
Flattened	175 lb/cu yd
<u>Plastics:</u>	
<u>Typical Densities</u>	
PET, Whole	34 lb/cu yd
PET, Flattened	75 lb/cu yd
HDPE (Natural), Whole	30 lb/cu yd
HDPE (Natural), Flattened	65 lb/cu yd
HDPE (Colored), Whole	45 lb/cu yd
HDPE (Colored), Flattened	90 lb/cu yd
<u>Tin Plated Steel Cans</u>	
Whole	150 lb/cu yd
Flattened	850 lb/cu yd

proximately 40% of its residents fly south for the winter, and plays host to an influx of vacationers every summer.

A regional approach was established for material recovery which targets source separated materials in an effort to encourage participation, consolidate marketing of materials, and reduce transportation and administrative costs.

The facility was designed to process up to 300 TPD of aluminum, glass, PET, HDPE, ferrous, OCC, mixed

paper, and ONP. The facility operates on a two-shift per day basis utilizing two distinct processing systems, one for mixed paper and one for commingled containers.

The construction cost for the project was \$7.4 million with the first year operating cost of \$1.2 million. The plant operator, Resource Recycling Technologies receives a fee for operating the plant. Revenues generated by materials marketed are on a shared basis; 5% to RRT and 95% to the County. The facility is owned by Ocean County and was designed, constructed and operated by RRT and its subsidiaries. The facility completed a rigorous acceptance test on July 25, 1991, well ahead of schedule.

The newly constructed recycling facility consists of approximately 35,000 sq. ft of combined tipping and processing area and a 1800 sq. ft detached administration building.

### **Paper Processing**

During final design in the Summer of 1990, Ocean County had been experiencing difficulties in marketing ONP, which was part of their interim recycling program. ONP makes up approximately 70% of the total recyclable stream. The increase in recycling projects and supply of material has drastically reduced the market price of ONP to a negative revenue position. This led the County to work with Garden State Paper Company to formalize a 10-year contract that would establish a positive base price of \$20/ton for the majority of its ONP. The facility would be required to sort additional grades of paper as well as incoming commercial paper streams. These considerations led to a custom redesign of the paper sorting system.

As a condition of the long term contract, the facility would be required to produce a near Number 8 special news product to be shipped loose. For MRFs, there are essentially two main categories for newsprint, a Number 8 special news deinking quality and a Number 6 news. The Number 8 designation varies from Number 6 news in greater stringency with regard to the number of rejects allowed, which is limited to 0.25% prohibitive materials [3]. Prohibitive materials include items that can damage the paper mill equipment or are unsuitable for that specific grade.

With the expansion of the collection program and the use of market specifications as part of the design goal, we set out to engineer a very advanced paper sorting system. The original design was based on a residential incoming stream consisting of primarily newspaper which would be sorted as a Number 6 news pack, baled, then marketed on a spot basis. The new

design required a higher degree of automation to facilitate the flexibility of sorting various grades of both residential and commercial waste paper while also being capable of producing both baled and loose end products as follows:

(a) Accept various grades of paper from residential and commercial sources including ONP, OCC, and mixed paper.

(b) Produce a Number 8 news product from mixed paper.

(c) Ship 150 TPD of baled or loose paper for market flexibility.

(d) Maximize facility revenues.

(e) Separate and process bulky OCC from incoming loads.

(f) Automatically spread the paper to a uniform burden depth where high speed sorting can be accomplished.

(g) Provide adequate surge capacity, since the baler is also used to process 30 TPD of various plastics produced from the commingled sorting system.

(h) Minimize changes to the building design.

(i) Minimize residue.

Working closely with in-house designers, suppliers and plant operators, a customized series of conveyors and sorting stations was engineered. The process begins with vehicles entering into the tipping hall and discharging the contents in close proximity to the infeed conveyors. A Case 621 front-end loader is used to feed predominantly newspaper material into the horizontal in-floor conveyor loading section. Corrugated-rich loads are segregated on the tipping floor and processed independently. As illustrated in Fig. 1, the sorting system is capable of processing 10–15 TPH of any composition of mixed paper. The system allows sorters to perform primary sorting of large corrugated materials, break bundles and remove plastic film (often used for bagging news) from two sides of an 11-ft long horizontal conveyor section. Depending on the type of material being processed, this station can be manned as required using removable side-skirts. Secondary sorting of mixed paper is performed from an elevated platform utilizing drive-through bunkers located below. Bunker designations are interchangeable to allow for variations of mixed paper and provide system flexibility.

The sorting platform is situated 14 ft above the concrete floor with enclosure walls forming an elevated room complete with HVAC, windows, stair access, lighting and fire protection. The environmentally controlled room was designed for worker comfort to maximize productivity. The paper system consists of ergonomically designed sorting stations with waist high sorting conveyors and specially designed discharge

chutes which allow sorters to drop materials into storage compartments below. To maintain staffing flexibility, a 28-ft long conveyor was supplied. For safety, sorters are required to wear eye, ear, respiratory, foot and hand protection.

The paper processing system design consists of an independent baling process line and an independent sorting line with the following key features:

(a) The three separate sorting conveyors each operate at different speeds to reduce burden depths and maximize material sorting efficiencies.

(b) Two sorting stations are provided. The primary sort station removes large bulky corrugated and contaminants, and is used to break apart bundles of residentially collected news. The secondary sort station is the elevated platform as previously described.

(c) Three drive-through bunkers for material storage are located below the elevated sorting platform.

(d) Two transfer conveyors are provided under the platform to transfer material to a storage bunker or live bottom storage container.

(e) A live bottom storage container is located at the end of the sorting line to collect the “negatively” sorted materials and to automatically feed material to the baler infeed conveyor.

(f) A loose news loadout conveyor to transfer material to a stockpile location for material loadout to trailers.

After passing through the primary sort station the paper continues up the inclined conveyor number 2 and is metered onto conveyor number 3. Several transitions were designed into the system to automatically turn over the paper so the underside of the burden can be inspected and to spread the paper to a relatively uniform burden depth. Conveyor number 3 is 48-in. wide to allow sorting from both sides and is equipped with a variable speed drive to maximize worker productivity and provide flexibility for various mixes of incoming material. Materials are sorted from conveyor number 3 and deposited in drive-through bunkers below. The bunkers were sized to allow material to be stored sufficiently and then batch fed in sequence by skid-steer to the baler infeed conveyor. The last and final positive sort will depend on the mix of incoming material. If material is generally clean ONP, then any mixed paper will be removed and deposited below by storage conveyor number 4. The remaining ONP will, therefore, be made into de-ink quality Number 8 ONP by a negative sort. Conversely, if the incoming material is a mixture of many grades in addition to ONP, then ONP will be positively sorted into a Number 8 grade and the negative sort will be mixed paper. Since each of these last two sorts may be for ONP, conveyors 4 and 5 are

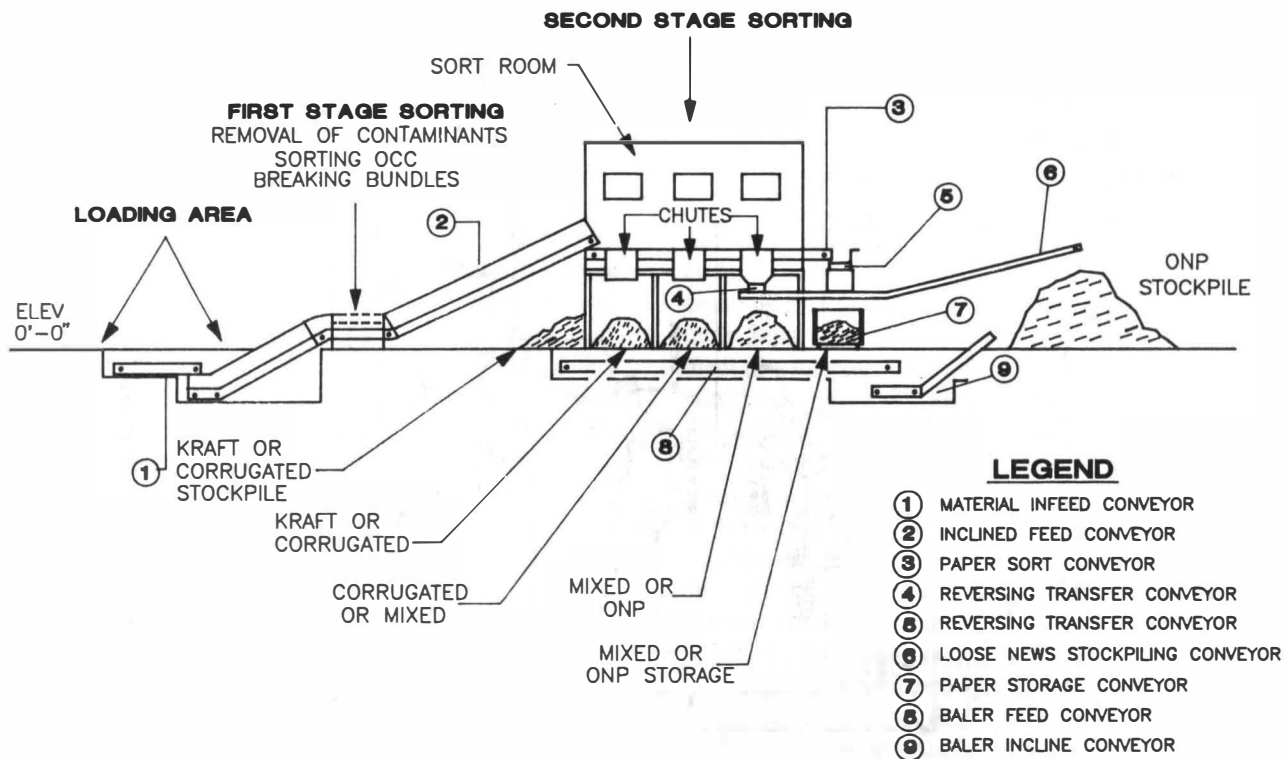

FIG. 1 OCEAN COUNTY, NEW JERSEY PAPER PROCESSING SYSTEM

provided for either filling the drive-through storage bunker, the live bottom storage container number 7, or for transferring loose ONP to the loadout storage area. This is achieved by the reversible drives on conveyors 4 and 5. The sorted Number 8 ONP will be transferred by conveyor number 6 to a loose ONP loadout area for consolidation and shipment.

Material collected in the drive-through bunkers and live bottom storage container number 7 can be fed into the horizontal pit mounted section of the baler feed conveyor number 8. This transfers material onto the inclined paper baler infeed conveyor number 9, which feeds a Bollegraaf HBC-80 baler capable of processing an average of 17 TPH of newspaper. The baler was chosen for its ability to process the material from the paper sorting system, as well as batch feeding two colors of PET and HDPE containers separated by use of the commingled sorting system.

The paper sorting system has proven its ability to give the client and operators the flexibility in positively and negatively sorting paper to specific market grades under changing incoming compositions.

## COMMINGLED RECYCLABLES PROCESSING

The process design for the commingled sorting system is based on a proven processing system which is depicted in the Process Flow Diagram (Fig. 2). The custom designed 150-TPD system integrates both manual and automatic sorting techniques whereby approximately 75% of the recyclable material is automatically sorted without sacrificing quality. The remaining sorting procedures are done manually in an environmentally controlled room to maximize worker comfort and increase productivity. The result is that a high ratio of market revenue to operating costs is achieved while generating a very low level of process residue.

The dual infeed line system allows maximum sorting flexibility with two independent processing lines. It is initiated by the skid steer loader operator who directs the material from the tipping and storage areas into either of the two receiving hoppers. The two identical processing lines, each having 75% of plant capability, enable the plant to continue operating should a single line experience unscheduled downtime. Other advantages of a dual line system approach are increased flex-

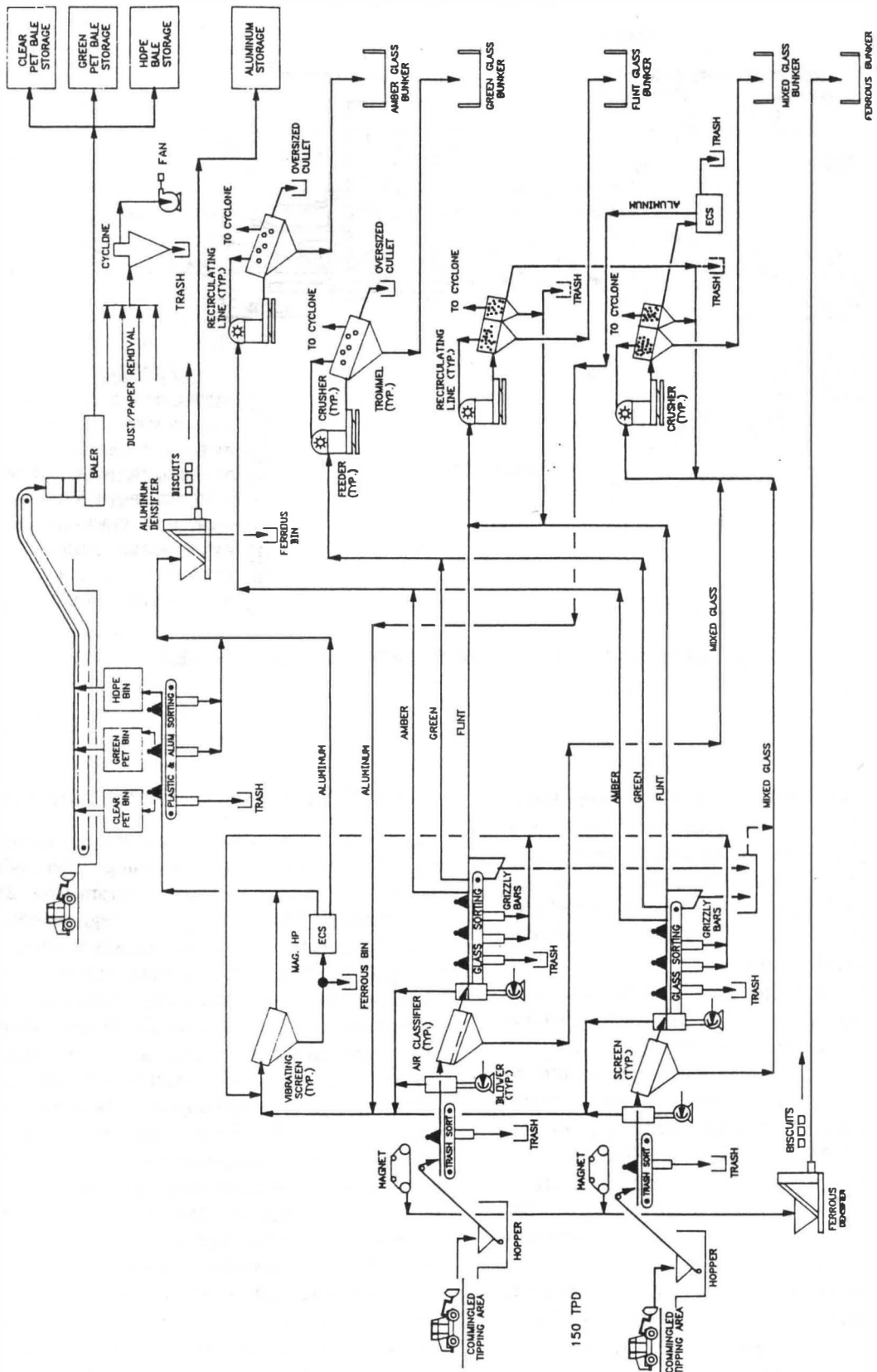

FIG. 2 OCEAN COUNTY, NEW JERSEY COMMINGLED SYSTEM PROCESS FLOW DIAGRAM

ibility in manning and production scheduling during seasonal changes.

Material is automatically transferred from the receiving hoppers and elevated to the initial processing step of magnetic separation by means of two corrugated sidewall conveyors. The suspended electromagnetic separator automatically removes tinned ferrous, aerosol cans, and bi-metal cans and other tramp ferrous material from the recyclables stream. The self-cleaning magnets are located using an in-line configuration, however, the belt direction is counter-flow, thus providing more retention time within the magnetic field. Recovered material is conveyed to an automatic densifier which produces 70-lb biscuits to be shipped to market.

The remaining commingled recyclables pass by an inspection station for removal of nonrecyclables, such as: ceramics, PVC, plastic film, paper, plate glass, and vinyl records. Each inspection station is equipped with variable speed drive frequency controllers to allow for various belt speeds to ensure proper quality control and material flow. The remaining materials are directed to the next step in the process, which is designed to separate the bulkier light recyclables from the heavy and denser fractions. The light fraction stream, consisting primarily of aluminum and plastic containers, is separated from the heavy glass fraction by a primary air classifier. This horizontal air classifier utilizes the same cross air flow principle as the Bureau of Mines and Boeing horizontal classifiers [4]. The light fraction is entrained in an air stream as the aluminum and plastic containers discharge from the inspection station conveyor. By removing light bulky plastics such as milk jugs, detergent and large soft drink containers the burden depth is reduced and improves subsequent screening.

Following separation, the heavy fraction is directed by chute to a vibrating screen specially designed for the automatic separation of small pieces of broken glass containers. The counter-balanced screen is equipped with an impact area and several stepped grizzly screen sections which cause material to roll-over as they pass through. A vibrating screen was chosen to minimize the breakage of whole glass containers and thus reduce the mixed broken glass stream. The separated material, due to its size, is not color sorted but, as described later, is processed downstream into a marketable aggregate product. By removing the broken glass at this stage, downstream sorting is significantly improved allowing whole containers to be safely sorted. The remaining oversized material on the screen is metered to the secondary air classifier, thus separating remaining amounts of aluminum and plastic. To adjust the air flows on the primary air classifier and reduce the

amounts of broken glass becoming entrained in the air stream, a variable speed drive mechanism was attached.

The light fraction, consisting of aluminum and plastic, is collected from the two air classifiers and is conveyed to a vibratory grizzly screen to separate large plastic containers from smaller aluminum and plastic. As in the case of the mixed glass separation screen, each deck is designed with flared bars to minimize material jams. The reduced stream is fed into a specially designed 36-in. wide eddy-current separator for automatic separation of aluminum from plastic. This equipment was selected after performing an equipment/manpower cost analysis to determine overall savings based on the specific recyclables composition and amount of aluminum which would otherwise require manual sorting. This equipment has been tested to achieve a 90% recovery of aluminum UBC. The aluminum is fed directly into a densifier while the two plastic streams are collected into a surge hopper that feeds the plastic sorting conveyor. Additional design considerations should be given for placement of a perforating device which is dependent on baler selection and recyclables composition. The sorting conveyor is located in the common elevated environmentally controlled sort room, which also includes the glass sort conveyor. Sorters positioned along the length of the sorting conveyor positively sort the PET containers and colored HDPE and place them in the designated storage bins. Each of the storage bins is designed with a sloped bottom and electrically operated slide gates for easy unloading of material and is sized to store enough material for several bales. The clear HDPE containers are negatively sorted and discharge from the sorting conveyor into another storage bin. The negative sorted material is selected based on the large number of containers in the recycling stream, thus minimizing the amount of positive sorting required. In this manner, operating manpower requirements have been significantly reduced over systems which perform all positive sorting. The sorters will also remove contaminants from the conveyor and place them in containers for disposal. The stored plastic containers are then fed directly in batch sequence to the baler feed conveyor. The system is designed utilizing a single baler to handle both paper and plastics. Traditional methods have used a single baler, single material approach. Using one baler for multiple materials maximizes space utilization and eliminates a multitude of material handling conveyors.

Returning upstream in the process and continuing from the secondary air classifier, the heavy fraction of the recyclable stream, consisting primarily of glass containers, passes through the air stream and continues onto the glass sort conveyor. Sorters positioned along



the 60-in. wide compartmentalized conveyor positively sort green and amber colored glass containers. The belt has been sized to prevent jamming by providing sorting lanes capable of handling large glass containers such as wine jugs. The predominant material, flint glass, is left on the mechanical sorting table as a negative sort. Additional chutes are provided on each sorting line for the collection of trace amounts of plastic and aluminum which were missed by the air classifiers; these materials are conveyed to the eddy-current separators for automatic separation. The negatively sorted flint glass discharged from the sorting conveyor is fed directly onto a stationary grizzly screen used for final screening to remove broken glass and small contaminants. The three separated streams of containers are conveyed to color designated crushing and beneficiation subsystems which produce market acceptable furnace-ready cullet.

### Glass Beneficiation

This facility boasts one of the lowest residue percentages in the industry, with average processing residue at 2%, significantly below the contract guaranteed rate of 5.5%. Due to the multiple handling associated with loading, transporting and tipping of glass containers, as much as 60% of the total glass may be received broken at the facility. This breakage is typical of most MRFs. Since this material cannot be cost-effectively color sorted, most other facilities discard this material as residue and maintain residue levels approaching 20%. An automatic mixed broken glass beneficiation system was developed to clean and sell the glass material as an aggregate product used in the making of asphalt. This product meets the stringent requirements set forth by the NYC DOT for incoming material for its glassphalt plant. While this material does not present a strong market value, it does contribute to overall plant performance by reducing residue disposal costs.

The mixed broken glass is collected in two ways throughout the plant. Material is collected by stationary grizzly bars at the discharge of the glass sorting conveyor and by the vibrating screen located after the primary air sort. This material is conveyed to a centrally located beneficiation subsystem. The subsystem is a modular unit that automatically beneficiates the mixed broken glass at a rate of 5 TPH with a 98% glass recovery rate.

A key factor in the design of this system was developing a crusher which could obtain a fine particle size for glass but keep the caps, tabs, rings and other contaminants intact. Other miscellaneous contaminants include flattened aluminum and plastics which pass

TABLE 3 CRUSHER SIEVE ANALYSIS DATA

Screen Size	Test	Test	Test	Average
	No. 1	No. 2	No. 3	Percent Passing
	(Percent)			
1"	99.4	100.0	99.9	99.8%
3/4"	98.9	99.7	99.5	99.4%
5/8"	98.4	99.2	98.1	98.6%
1/2"	97.9	98.6	96.6	97.7%

through the vibratory grizzly screen. Other factors considered in the design were:

- (a) Low maintenance.
- (b) Low noise.
- (c) Resistance to highly abrasive glass.
- (d) Ability to handle non-uniform feed rates.
- (e) Ability to handle plastic, aluminum and gallon

HDPE jugs.

A long equipment search was initiated, after significant testing a crusher was customized and purchased under an exclusive agreement. The subsystem design begins with the material being collected throughout the plant and fed onto an inclined conveyor en route to the crusher. These glass handling conveyors are equipped with self-adjusting scrapers and self-cleaning wing type return idlers to minimize belt wear.

The single row cage mill crusher breaks the glass into a fairly consistent particle size of minus 1/2 in. as shown on the sieve analysis data in Table 3. The crusher, with its specially designed discharge box and a vibratory feeder in combination, performs the initial sizing of the material. Secondary sizing is performed by a two-stage trommel (Fig. 3). To minimize wear and maintenance, the crusher is connected through a PLC and timers which automatically reverses its direction on a daily basis. This was designed to obtain uniform wearing of the crushing bars and promote longer wear life.

The crushed materials discharge into a stone-box which allows material to build up inside of the box to form a lining of glass. The entire box is designed utilizing abrasive resistant steel to protect the uncovered portions. The original box made from mild steel showed signs of wear after only months of service.

The counter-balanced vibratory feeder allows the glass to be metered into the trommel screen. To assist maintenance personnel in clearing jams caused by occasional surges of wet material, the equipment incorporates a lexan viewpoint and quick release clamps on both the dust cover and hinged cleanout door located at the rear of the vibrating pan.



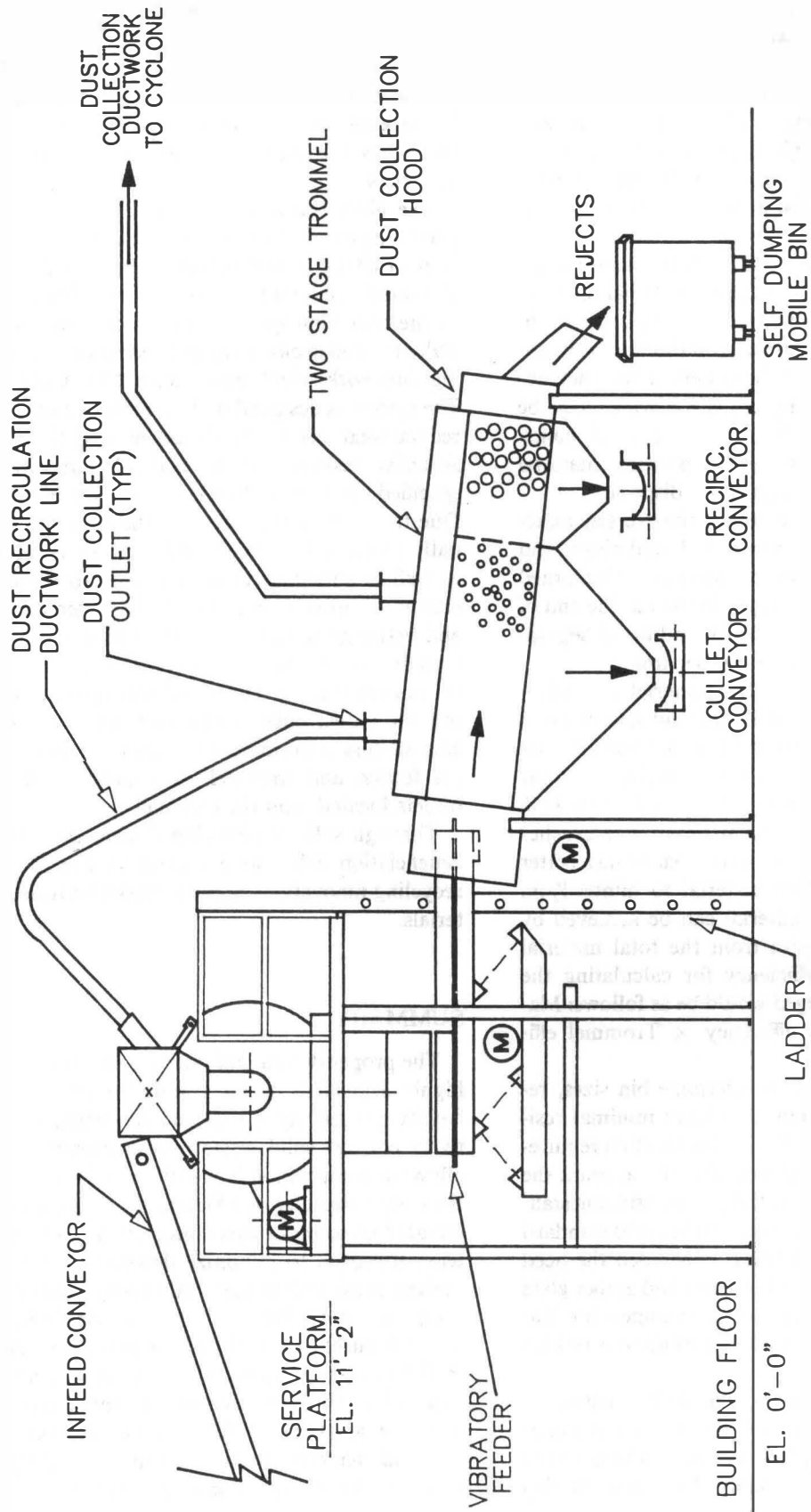

**LEGEND**

(M) = MOTOR

FIG. 3 OCEAN COUNTY, NEW JERSEY GLASS BENEFICIATION SYSTEM

The glass material is discharged by the vibratory feeder and metered into a two-stage trommel screen for secondary sizing. A dual trunnion drive is utilized to rotate the 10-ft long by 30-in. diameter screen to a speed of 27 rpm. The self-cleaning totally enclosed trommel is designed to properly size glass, which is conveyed to a covered outdoor concrete bunker for shipment to market. The mid-sized material is collected by conveyors and recirculated to the crusher for resizing. The material, having a combination of glass and contaminants, is recirculated to achieve the maximum material recovery possible. Since the process is closed looped, it is periodically purged to remove the accumulation of contaminants that continue through the system. This is accomplished through a reversing conveyor which can be controlled directly from the master control panel. When the conveyor is in the reverse position, material flows into a self-dumping hopper for disposal.

Continuing through the trommel, the oversize material, consisting primarily of paper labels and plastic and aluminum lids, tabs, rings and enclosures, is discharged either into a self-dumping hopper located at the end of the trommel or onto a conveyor for additional separation through a 12-in. eddy-current separator.

The determination to recirculate material is based on developing a material balance for each subsystem based on the performance of the individual components and the quantities to be processed. For example: the single stage trommel screen has been tested to achieve a 93% screening rate for minus ½-in. material. The crusher has been tested with sieve analysis data showing a better than 97% ability to reduce material to minus ½-in. Calculating the oversize material can be achieved by subtraction of the undersize from the total material stream. The combined efficiency for calculating the amount of unders discharged would be as follows: Material (TPH) × Crusher efficiency × Trommel efficiency.

This calculation is used to determine bin sizes, requirements for recirculation to achieve minimal residue, and for determining additional separation requirements. This calculation does not take into account the fact that sieve analyses are typically done utilizing standard square mesh and the trommel screen uses standard diameter hole sizes. This analysis concluded the need for single-stage trommels for the green and amber glass beneficiation systems and two-stage trommels for flint and mixed broken glass to achieve a minimum residue level.

In the case of Ocean County, where the recovery of aluminum was to be maximized, the oversize material discharging from the flint line was recirculated to the mixed glass beneficiation system. The material dis-

charged from the mixed glass trommel oversize stream is conveyed to an additional 12-in. eddy-current separator for the further recovery of aluminum. This was designed to both minimize residue and enhance marketing revenues because aluminum, on a price per pound basis, has the highest market value of all recovered materials.

The glass beneficiation system is connected to the plant's dust collection and fines removal system. Dust from crushing as well as paper labels, small plastic and aluminum rings and tabs are removed from the stream by the collection system. The system consists of a centrally located cyclone, fan and associated interconnecting ductwork which generates a 1500 CFM air flow. The system is designed with minimal transfer points to reduce wear due to the abrasiveness of the glass dust. Abrasive resistant elbows and inlet transitions were specified, as well as bleeder valves for air balancing. Due to the abrasive nature of the material, the originally specified hot rolled steel cyclones didn't hold up as well as anticipated and required retrofitting with a rubber compound liner to obtain lower maintenance and better anticipated life. As in most dust collection systems, sealing the system is the most important rule of containment [5]. The infeed conveyor to the crusher utilizes a dust curtain and dust seal combination to control dust at the inlet. The crusher, stone-box, vibrating feeder, and trommel are enclosed, with exhaust outlets located atop the trommel.

Through solid engineering design, the mixed glass beneficiation sub-system represents one of the latest recycling innovations used to maximize recovered materials.

## SUMMARY

The proper design and ultimate success of a MRF is highly dependent on integrating the key components: facility, process equipment and marketing to cost effectively convert solid waste into marketable scrap. To allow for composition fluctuations and material surges, the design capacity of a facility should be greater than its rated throughput while integrating a redundant systems approach to minimize downtime. Cost effective designs must utilize space effectively while providing adequate room for maintenance, employee access, safety features, material storage, and future flexibility.

The proper selection of equipment to perform reliably and maintain excellent quality levels is a key design feature in MRFs of the future. As equipment technologies and markets evolve, so will MRF designs with enhanced flexibility to process a variety of incoming

materials. As more recycling facilities come on line, the greater amount of materials being recovered will assist in achieving the national goal of preserving our natural resources and protecting the environment for future generations.

## REFERENCES

[1] "Recycling in the States," National Solid Wastes Management Association, 1989.

[2] Egosi, N. April 1989, "Design Considerations for Intermediate Processing Facilities," *Journal of Resource Management and Technology*, 17, 2, April 1989, 92-97.

[3] *Paper Stock Institute of America*, Paper Stock Standards and Practices, 1986.

[4] Hasselriis, F. "Refuse Derived Fuel Processing," Stoneham, Massachusetts: Butterworth Publishers, 1984, p. 189.

[5] Mody, V. et al. *Dust Control Handbook Pollution Technology Review No. 161*, Park Ridge, New Jersey: Noyes Data Corporation, 1988.