

# DESIGN CONCEPTS TO MINIMIZE SUPERHEATER CORROSION IN MUNICIPAL WASTE COMBUSTORS (An Overview)

**ANTHONY J. LICATA**  
Dravo Energy Resources, Inc.  
New York City, New York

**ROBERT W. HERBERT**  
Dravo Engineering Companies  
Pittsburgh, Pennsylvania

**ULRICH KAISER**  
L&C Steinmuller GmbH  
Gummersbach, Federal Republic of Germany

## INTRODUCTION

For many years fireside corrosion, erosion and erosion/corrosion problems have plagued superheater designs in municipal waste combustors (MWC). Many unscheduled outages are the result of superheater tube failures caused by fireside initiated tube metal wastage. Prior to 1980, little attention was paid to erosion; the primary concern was with high temperature corrosion. Superheater corrosion was prevented by controlling chloride ( $\text{Cl}^-$ ) corrosion — which dictated steam temperatures under 750°F in order to limit the tube surface temperature. However, the units in operation prior to 1980 were boilers of either first or second generation design which did not have the high combustion efficiencies of the boilers being operated today. Units built after 1980 have stressed good combustion techniques that encompass designs for fireside corrosion, erosion, and erosion/corrosion controls. During the past 10 years the industry has seen a rise in the number of plants that have superheaters operating at steam temperatures in the range of 825–900°F.

For over a century L&C Steinmuller, GmbH, Gummersbach, Federal Republic of Germany has planned, designed and constructed plants covering every aspect of heat technology. Through a continual research and development effort, Steinmuller has studied the causes and the effects of fireside corrosion, erosion and erosion/corrosion of superheater tubes. These research

programs have not been limited to laboratory testing; they have also included pilot plant and operating commercial plant data gathering. These studies have led to the development of specific design concepts for minimizing the effects of those superheater problems.

Good boiler design and combustion can mitigate the need for tube cladding and high nickel alloys for the prevention of superheater corrosion and erosion. This paper will discuss design concepts which can be employed to minimize corrosion, resulting in lower maintenance costs and higher plant availability.

## FACTORS INFLUENCING SUPERHEATER PROBLEMS

The predominant factors influencing fireside corrosion, erosion or erosion/corrosion problems in MWC superheaters that exceed steam temperatures of 750°F are as follows:

- (a) Excessive gas velocities.
- (b) Sootblowing with air or steam that exposes fresh metal surfaces or cuts the tubes by a sawing effect caused by steam jet and entrained dust.
- (c) Gas stratification that results in a reducing atmosphere and an uneven temperature profile.
- (d) Incomplete combustion resulting in higher levels of CO and particulates in the flue gas stream.

(e) Chlorides which cause “below deposit” corrosion.

(f) Excessive metal temperature.

(g) Exposure to radiant heat.

(h) Improper sizing of superheater.

(i) Improper material selection.

While considering the above factors, a number of boiler design concepts can be incorporated to minimize superheater corrosion for those MWCs requiring steam temperatures in excess of 750°F, the traditional upper limit for those types of boilers. The concept of designing to minimize superheater corrosion may be an effective alternative to a metallurgical tube material upgrade from low alloy steel to high performance alloys. Without penalizing boiler efficiency, these concepts attempt to minimize the occurrences of those operational conditions and the formation of those environments known to influence fireside corrosion, erosion or erosion/corrosion of MWC superheaters that exceed steam temperatures of 750°F.

Many other operating factors, such as the procedure to laying up a boiler, can contribute to corrosion; this paper will not discuss those factors.

## DESIGN CONCEPTS

### Gas Velocities

Since erosion results from the impact of particulates entrained in the flue gas, higher gas velocities through the superheater will result in a more severe erosion action. Industry practice has demonstrated that the gas velocities should be held between 15 and 18 ft/sec in the superheater section of MWC boilers. A horizontal superheater section with vertically mounted tubes (see Fig. 1) can be used to avoid the natural particle velocity increases which result from the downward gas flow typically experienced with vertical superheaters where tubes are horizontally mounted. Figure 2 presents the general boiler design criteria for velocities and temperatures that are used for corrosion/erosion control. In addition, since the close tube spacing common with vertical superheaters results in higher gas velocities, a design utilizing liberal tube spacing can mitigate the effects of particulate erosion.

Furthermore, liberal tube spacing also mitigates velocity increases from ash buildup fouling. A typical superheater is presented in Fig. 3.

### Sootblowing

Ash removal is required to prevent buildup that can affect the heat transfer properties of superheater tubes

and result in overheating failures. Without ash removal, the gas flow area becomes restricted, thus increasing both gas velocity and the potential for metal wastage due to particulate erosion. Furthermore, depending on the chemical species present, rapid corrosive attack may occur at the interface of the metal and the ash deposit.

Steam and air sootblower systems are most commonly used for ash removal. However, a mechanical pneumatically actuated individual rapping system can be incorporated into vertical tube superheaters arranged in a horizontal convective pass. The rappers cause the ash deposits to slide down the tube surfaces and into ash hoppers located below each superheater section (see Fig. 4). This avoids ash reentrainment into the flue gas and subsequent deposition onto the downstream superheater surfaces. The gentle rapping action removes the excess fly ash from the tubes, while leaving a thin protective coating of ash.

More importantly, rapping does not disrupt the protective oxide film layer on the tubes. Steam sootblowing may strip the protective oxide layer from the tubes thus exposing fresh clean metal to the corrosive and/or erosion flue gas and accelerates the corrosion rate.

When steam sootblowers are utilized, the tubes are not uniformly cleaned and hot spots from uneven heating of the metal surface may occur. Steam sootblowing may also add moisture to the surface of deposit buildup on the tubes; this may increase the rate of metal wastage due to corrosion. Misalignment or improper positioning of steam sootblowers can cause premature erosion/corrosion tube failures due to steam cutting.

Utilization of a rapping system design provides for a more uniform tube cleaning without the introduction of moisture and eliminates the possibility of tube failure resulting from the ash removal procedure itself.

A MWC boiler with a three pass vertical design minimizes carry over of the “sticking” fly ash particles into the superheater. This is accomplished as follows:

(a) Fallout of large fly ash particles from the gas stream between passes 2 and 3.

(b) Maintaining temperatures at a level where the adhesion of the particles is minimized.

### Gas Stratification

The potential for gas stratification can be minimized by a boiler design that requires the flue gases to make multiple radiant gas passes through two 180 deg. turns and one 90 deg. turn prior to entering the superheaters. These turns result in optimum mixing of the gases, and practically eliminate the entrance of pockets of CO into the superheater. These turns, in addition to

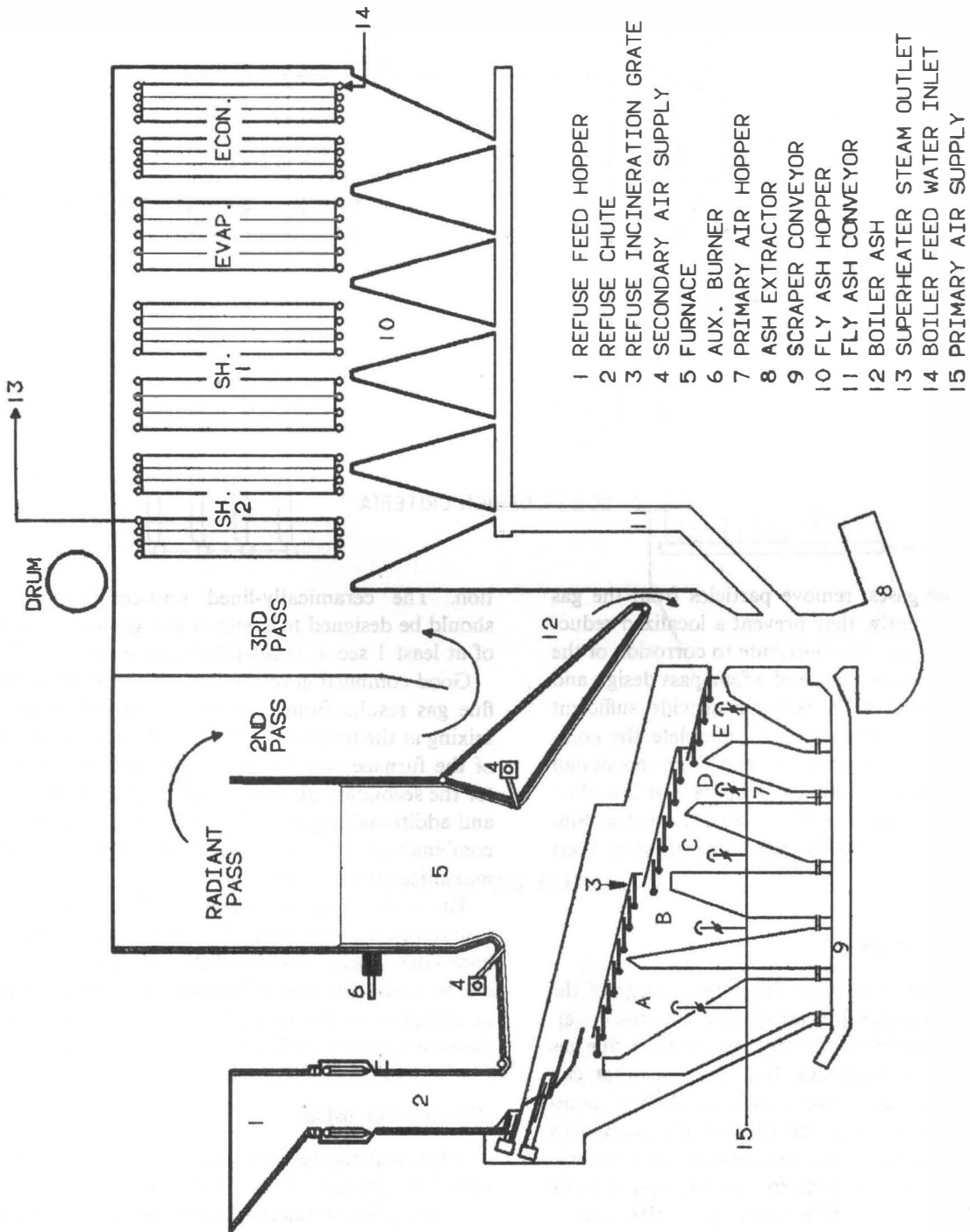

- 1 REFUSE FEED HOPPER
- 2 REFUSE CHUTE
- 3 REFUSE INCINERATION GRATE
- 4 SECONDARY AIR SUPPLY
- 5 FURNACE
- 6 AUX. BURNER
- 7 PRIMARY AIR HOPPER
- 8 ASH EXTRACTOR
- 9 SCRAPER CONVEYOR
- 10 FLY ASH HOPPER
- 11 FLY ASH CONVEYOR
- 12 BOILER ASH
- 13 SUPERHEATER STEAM OUTLET
- 14 BOILER FEED WATER INLET
- 15 PRIMARY AIR SUPPLY

FIGURE 1

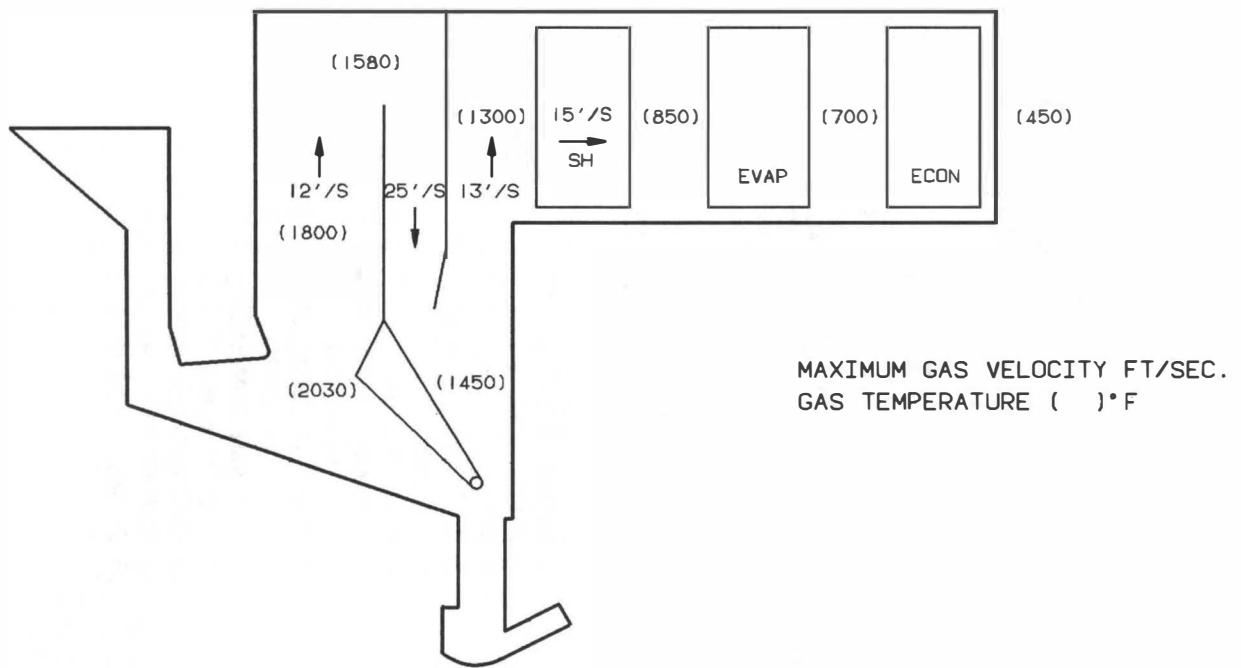

FIG. 2 BOILER DESIGN CRITERIA

mixing the flue gases, remove particles from the gas stream. Consequently, they prevent a localized reducing atmosphere that can contribute to corrosion of the tubes. The physical structure of a four-pass design and the introduction of secondary air provide sufficient turbulence and retention time to complete the combustion process. MWC units incorporating this design have demonstrated the ability to operate at less than 50 ppm CO [4]. This has been accomplished at Stapfeld and Herten in MWC units operating in West Germany.

### Incomplete Combustion

Good combustion involves the proper design of the stoker, under-and-over fired air systems, and the boiler.

Incomplete combustion produces a reducing flue gas environment containing CO, H<sub>2</sub>, H<sub>2</sub>S, etc. that can cause superheater corrosion problems. A total combustion system optimizes the process and minimizes the products resulting from incomplete combustion.

By designing MWC units to operate at excess air levels of 80–85% and CO emissions of 50 ppm, a combustion efficiency of 99.95% can be attained and can be taken as a guide value for high burnout quality. The evaporative-cooled furnace and the lower section of the adjoining vertical radiation pass (post-reaction zone) should be ceramically lined for thermal insula-

tion. The ceramically-lined post-combustion zone should be designed to ensure a flue gas residence time of at least 1 sec at temperatures in excess of 1800°F.

Good combustion of the volatile components in the flue gas results from turbulence and subsequent gas mixing at the boiler exit. This is achieved by the shape of the furnace and the design of the injection points for the secondary air system which provide turbulence and additional oxygen. The four pass boiler design, in combination with the overfire air injection system, maximizes the turbulence factor.

The ceramic lining and the high burnout quality achievable through state-of-the-art firing control systems have largely eliminated the risk of tube corrosion due to a reducing atmosphere within the furnace. Even at design pressures of up to 1000 psig, no excessive damage to water wall sections need be expected.

### Chloride Corrosion

When superheater tube wall metal surfaces are designed to operate above 750°F the risk of corrosion increases. The corrodents in this so-called “high-temperature corrosion mechanism” that cause superheater corrosion are the alkaline metallic chlorides produced during municipal refuse incineration (basic constituents: chlorine, potassium, sodium, etc.), which are initially transported as gaseous flue-gas constituents

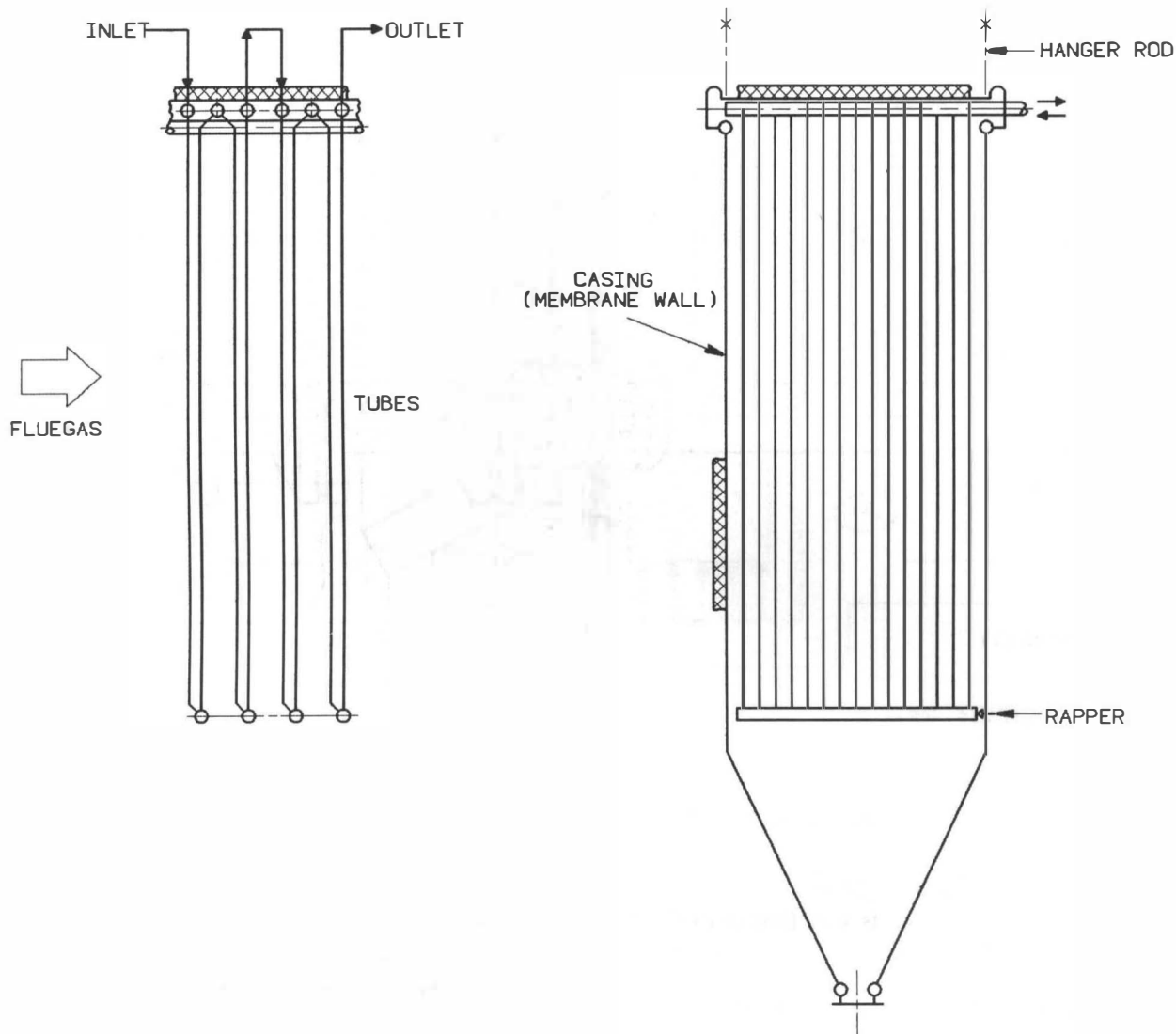
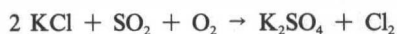

FIG. 3 TYPICAL SUPERHEATER

through the boiler passes in combination with  $\text{SO}_2$ ,  $\text{O}_2$ ,  $\text{H}_2\text{O}$ , and dust particles containing silicon compounds and traces of various other elements. These alkaline metallic chlorides react with the  $\text{SO}_2/\text{SO}_3$  contained in the flue gas to form alkali-sulfates. This is shown in simplified form as follows:



Sulfatation, the reaction of  $\text{SO}_2$  with the alkaline metallic chlorides (in the above equation,  $\text{KCl}$  is taken as representative of all the alkaline metallic chlorides concerned), liberates large quantities of elemental chlorine which combine with water vapor contained in the flue gas to form  $\text{HCl}$ .

If elemental chlorine comes into contact with the tube surfaces,  $\text{FeCl}_2$  is produced while oxygen is released. In this process, the hot protective oxide layer ( $\text{Fe}_3\text{O}_4/\text{Fe}_2\text{O}_3$ ) on the tube surfaces is destroyed.  $\text{FeCl}_2$  evaporates from clean tube surfaces. However, if the sulfatation reaction, as stated in the equation above, takes place within a layer of impurities adhering to the tube surface, evaporation of the  $\text{FeCl}_2$  is prevented and corrosion starts according to the following transformation cycle

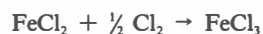

$\text{FeCl}_3$  at temperatures between  $570^\circ\text{F}$  to  $930^\circ\text{F}$  and together with water vapor again forms  $\text{HCl}$  and ele-

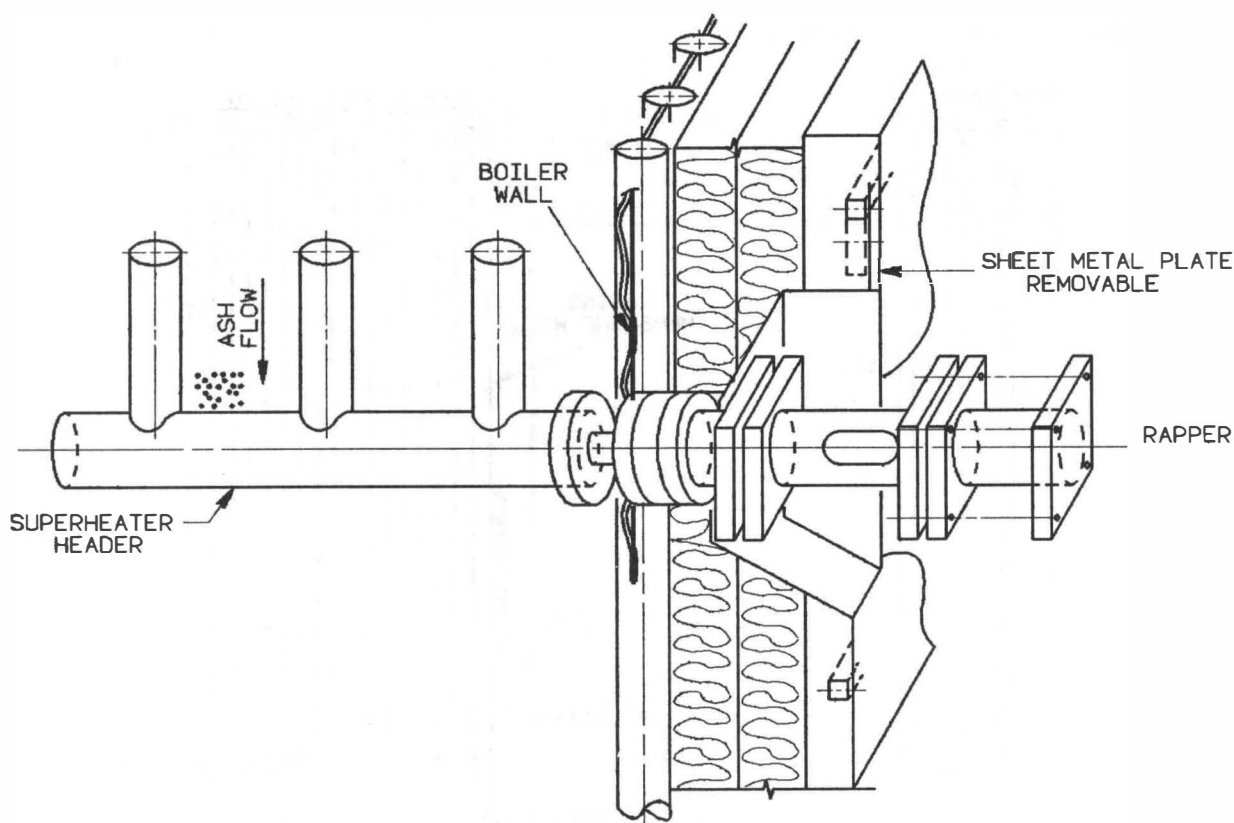
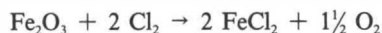

FIG. 4 RAPPER BOILER SUPERHEATER HEADERS

mental  $\text{Cl}_2$  which in turn reacts with ferrous oxide at the tube surface to form  $\text{FeCl}_2$ :



New formation of a "healing" ferrous oxide layer on the tube surface does not take place and corrosion of the tube wall proceeds at an accelerated rate. The results of tests from various sources [1-3] is that the transformation cycle described above is accelerated at high tube wall temperatures with a steep gradient at temperatures above  $860^\circ\text{F}$  that reaches a maximum at approximately  $1100^\circ\text{F}$ .

The following design concepts, proven through operating experience, can be incorporated into the design of MWC plants to minimize high temperature chloride corrosion problems.

(a) Radiation spaces in the steam generator should be designed for low flue gas velocities of 13-20 ft/sec. The objective here is to make available sufficient time for the reaction of all flue gas constituents so that the reactions producing alkali sulfates and elemental  $\text{Cl}_2$  are completed before the flue gases impinge on the first

convection heating surfaces. (Avoidance of  $\text{FeCl}_2$  formation on furnace walls as a result of elemental  $\text{Cl}_2$ ;  $\text{HCl}$  in the vapor phase is harmless by contrast).

(b) Incorporation of multiple radiant gas passes with 180 deg. deflections encourages the exchange between the flue gas constituents necessary for the transformation reactions in the gas phase.

(c) The flue gases emerging from the combustion chamber should be cooled by radiation to temperatures below  $1300^\circ\text{F}$  before entering the convection heating surface to avoid tenacious incrustations on the heating surfaces (cooling of the ash particles to below the initial deformation temperature). This, in turn, limits tube fouling by dust which only has a slight caking tendency and can be kept within the necessary limits by mechanical rapping cleaning equipment in the boiler. The avoidance, hereby, of tightly bonded tube deposits reduces the potential for "below deposit" corrosion.

#### Excessive Metal Temperatures

As previously stated, corrosion is accelerated at tube metal temperatures above  $860^\circ\text{F}$ , with the corrosion

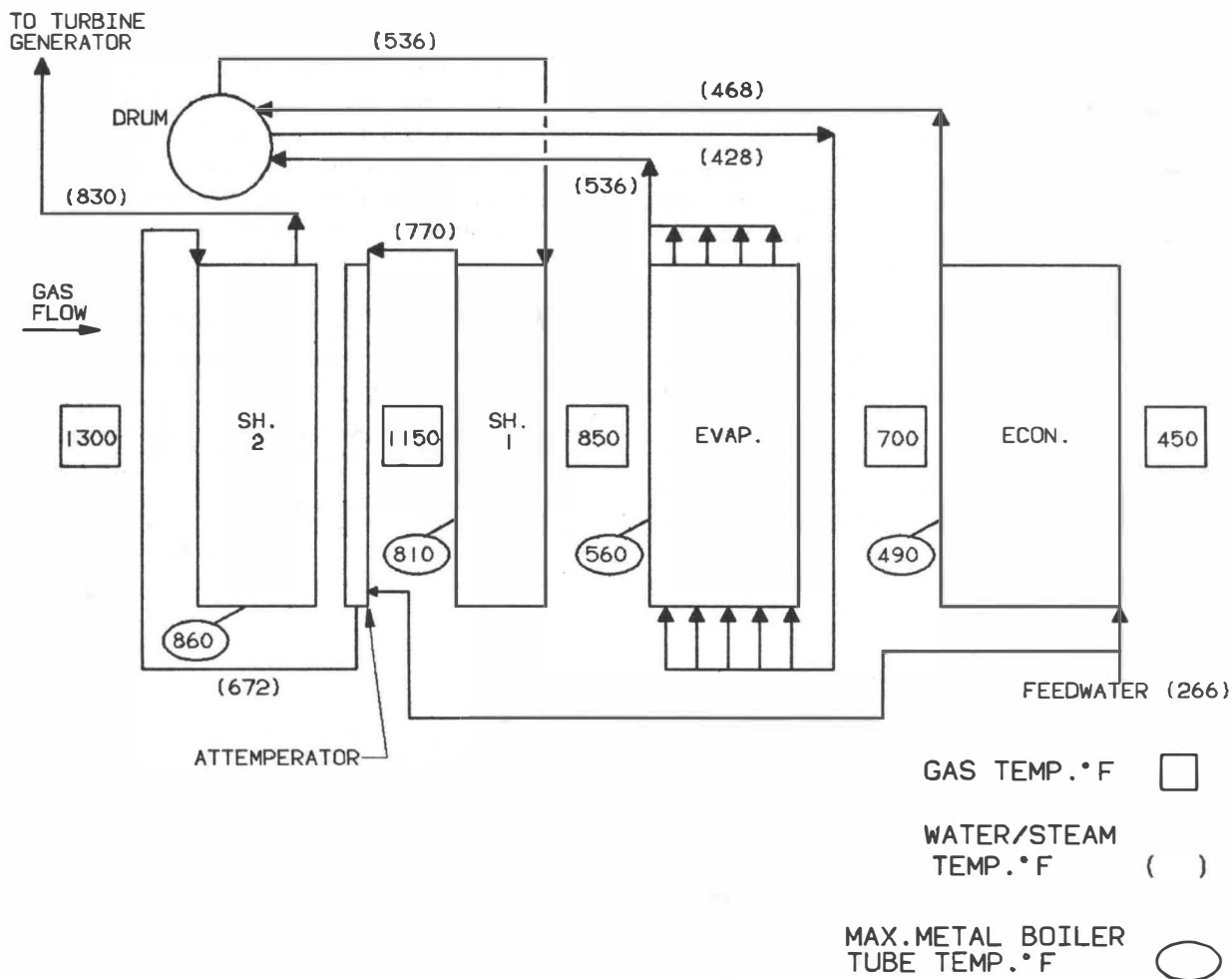

FIG. 5 BOILER WATER FLOW

rate reaching its maximum at a temperature of about 1100°F. By appropriate superheater design, as far as the location of the superheater surfaces and the superheat turndown ratio are concerned, the metal temperature of the final stage superheater can be kept below 900°F to reduce potential chemical reactions associated with the complex below deposit corrosion mechanism. Metal temperatures can be controlled by integrating a design of co-flow and counter-flow water/steam circuits through the convection sections of the boiler. Figure 5 presents a typical circuit used to limit metal temperature to 860°F while producing 830°F steam.

#### Exposure to Radiant Heat

If the superheater is located in the fourth pass, where it is completely shielded from the radiant heat, exces-

sive metal temperature can be avoided; thus reducing the superheater's susceptibility to corrosion.

#### Superheater Sizing

The superheater should be sized such that at 70% of the design steam flow (or the heat input), at least 100°F of superheat is maintained.

The US EPA, in its criteria for good combustion in MWCs, limits the turndown ratio to 80% of Maximum Continuous Rating (MCR). If a greater turndown ratio is used, an extended heating surface would have to be provided which increases the number of tubes subject to high temperature operating conditions. This, in turn, increases the danger of high temperature corrosion.

## Material Selection

Material selection should be based on a variety of factors including elements of design such as required service life, environment, operating conditions, allowable deformation, and cost. Material considerations such as corrosion resistance, mechanical properties and physical properties (thermal conductivity, thermal expansion, modulus of elasticity and transformation temperatures), also are factors.

ASTM A213 Grade T11 seamless tube material, also known as 1/4 Cr-1/2 MO low alloy steel, has been demonstrated to be an effective material when utilizing the aforementioned design concepts. The molybdenum is added principally to give higher strength; chromium is added to suppress graphitization and improve oxidation resistance and silicon is added to give further improvement in oxidation resistance.

## Summary

The design features, which have been incorporated into the combustion system for MWCs as outlined above, all contribute to minimizing the corrosion of superheater section tubes. This is an important consideration in maintaining high availability of the boiler while minimizing operating and maintenance costs.

## REFERENCES

- [1] Kirsch, and Pollmann, S. Hochtemperaturkorrosion Tahr- buch der Dampferzeugertechnik. Ausgabe 1970, 440-460
- [2] Kautz, K. and Tichatscke, J. Fuoammenhange Zurischen Rauchgasverhältnissen, Kesselbelastung und Korrosionen in einer Kommunalen Millvesbernnungsanlage. VGE Kraftwekstechnik 52 (no. 3, 1972).
- [3] Schirmer, U., Banmgarte, E., and Schroder, M. Die neue MVA Bielefeld-Herford—ein uber raschender Korrosionsfall.
- [4] L&C Steinmuller GmbH Internal Documents.